

INSTALLATION MANUAL FOR SSC-1500 CONTROL SYSTEMS ON PART- REVOLUTION-CLUTCH PRESS BRAKES

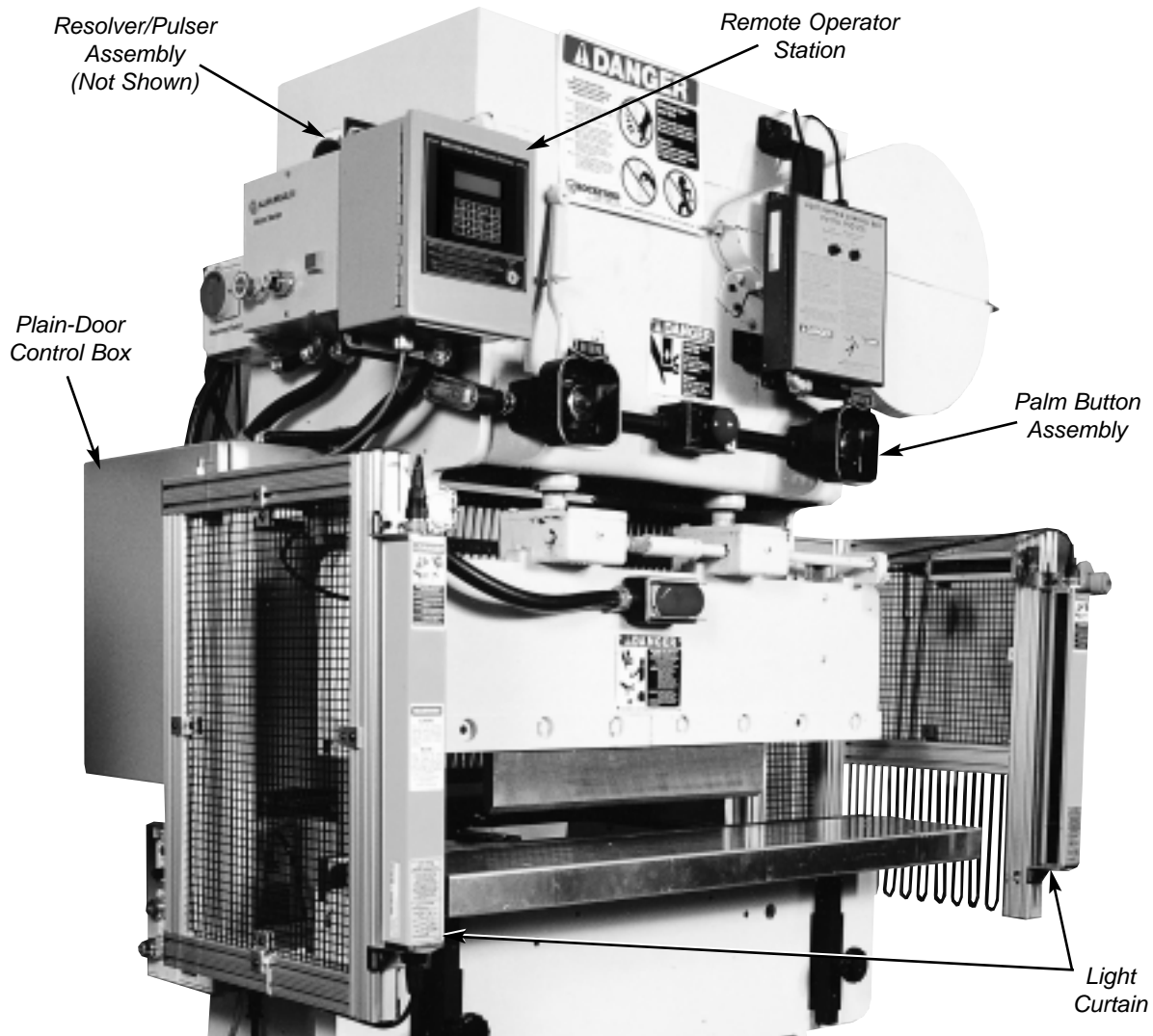

IMPORTANT: PLEASE REVIEW THIS ENTIRE PUBLICATION BEFORE INSTALLING, OPERATING, OR MAINTAINING THE SOLID-STATE CLUTCH/BRAKE CONTROL SYSTEM.

TABLE OF CONTENTS

SSC-1500 Part-Revolution Solid-State Control

SECTION 1—IN GENERAL	3-5
SECTION 2—INTRODUCTION	6-13
SECTION 3—INSTALLATION OF COMPONENTS	14-42
Introduction	14
Literature Folder	14-16
Control Box.....	16-24
Resolver/Pulser Assembly.....	25-26
Sprocket Assembly	27
Roller Chain.....	28
Monitored Dual-Solenoid Air Valve	28
Filter-Regulator-Lubricator (FRL) Assembly	28
Standard and Special Air Cylinders	29-30
Air Pressure Switch	30
Check Valve for Counterbalance System.....	30
Palm Button Assembly	31-35
Foot Switch.....	35-36
Supervisory Control Station.....	36
Multiple-Operator Junction Box	36
Other Components.....	37-40
Other Installation Considerations	40-42
SECTION 4—PROGRAMMING.....	43-73
User Inputs	46-49
Brake Monitor.....	50-52
Counters	53-54
System Setup.....	55-64
Angle Settings	65-66
Timed Settings.....	67
Optional Modes	68
PLS Output	69
Auxiliary Output	70-71
Quick Reference Table—Factory Settings and Valid Ranges.....	72-73
SECTION 5—FATAL AND GENERAL FAULT MESSAGES	74-77
SECTION 6—OPERATING CONSIDERATIONS.....	78-79
SECTION 7—MAINTENANCE AND INSPECTION.....	80-81
SECTION 8—REPLACEMENT PROCEDURES	82-84
SECTION 9—METHODS OF SAFEGUARDING.....	85-86
SECTION 10—RETURN MATERIALS AUTHORIZATION REQUEST FORM.....	87
SECTION 11—ORDER FORM FOR SIGNS AND LITERATURE.....	88

Safety Precautions

DANGER

DANGER indicates an imminently hazardous situation which, if not avoided, will result in death or serious injury.



This safety alert symbol identifies important safety messages in this manual. When you see this symbol, be alert to the possibility of personal injury, and carefully read the message that follows.

CAUTION

CAUTION used without the safety alert symbol indicates a potentially hazardous situation which, if not avoided, may result in property damage.

Efficient and safe machine operation depends on the development, implementation and enforcement of a safety program. This program requires, among other things, the proper selection of point-of-operation guards and safety devices for each particular job or operation and a thorough safety training program for all machine personnel. This program should include instruction on the proper operation of the machine, instruction on the point-of-operation guards and safety devices on the machine, and a regularly scheduled inspection and maintenance program.

Rules and procedures covering each aspect of your safety program should be developed and published both in an operator's safety manual, as well as in prominent places throughout the plant and on each machine. Some rules or instructions which must be conveyed to your personnel and incorporated in to your program include:

 DANGER **Never place your hands or any part of your body in this machine.**



Never operate this machine without proper eye, face and body protection.



Never operate this machine unless you are fully trained and instructed and unless you have read the instruction manual.



Never operate this machine if it is not working properly—stop operating it and advise your supervisor immediately.



Never use a foot switch to operate this machine unless a point-of-operation guard or device is provided and properly maintained.



Never operate this machine unless two-hand trip, two-hand control or presence-sensing device is installed at the proper safety distance. Consult your supervisor if you have any questions regarding the proper safety distance.



Never tamper with, rewire or bypass any control or component on this machine.

A company's safety program must involve everyone in the company, from top management to operators, since only as a group can any operational problems be identified and resolved. It is everyone's responsibility to implement and communicate the information and material contained in catalogs and instruction manuals to all persons involved in machine operation. If a language barrier or insufficient education would prevent a person from reading and understanding various literature available, it should be translated, read or interpreted to the person, with assurance that it is understood.



FOR MAINTENANCE AND INSPECTION ALWAYS REFER TO THE OEM'S (ORIGINAL EQUIPMENT MANUFACTURER'S) MAINTENANCE MANUAL OR OWNER'S MANUAL. If you do not have an owner's manual, please contact the original equipment manufacturer.

SECTION 1—IN GENERAL

SSC1500 Part-Revolution Solid-State Control

Safety References

OSH ACT AND FEDERAL REGULATIONS

Since the enclosed equipment can never overcome a mechanical deficiency, defect or malfunction in the machine itself, OSHA (Occupational Safety and Health Administration) has established certain safety regulations that the employers (users) must comply with so that the machines used in their plants, factories or facilities are thoroughly inspected and are in first-class operating condition before any of the enclosed equipment is installed.

1. U.S. Government—An Act—Public Law 91-596, 91st Congress, S. 2193, December 29, 1970:

Duties

SEC. 5. (a) Each employer—

(1) shall furnish to each of his employees employment and a place of employment which are free from recognized hazards that are causing or are likely to cause death or serious physical harm to his employees;

(2) shall comply with occupational safety and health standards promulgated under this Act.

(b) Each employee shall comply with occupational safety and health standards and all rules, regulations, and orders issued pursuant to this Act which are applicable to his own actions and conduct.

2. OSHA 29 CFR Sections that an employer (user) must comply with include:

1910.211 Definitions.

1910.212 General requirements for all machines.

1910.217 Mechanical power presses.

1910.219 Mechanical power-transmission apparatus.

3. OSHA 29 CFR 1910.147 The control of hazardous energy (lockout/tagout).

4. OSHA Publication

“General Industry Safety and Health Regulations Part 1910,” Code of Federal Regulations, Subpart O

This publication can be obtained by contacting:

Superintendent of Documents
U.S. Government Printing Office
P.O. Box 371954
Pittsburgh, PA 15250-7954
Phone: (202) 512-1800
Fax: (202) 512-2250
www.gpo.gov

ANSI SAFETY STANDARDS FOR MACHINES

The most complete safety standards for machine tools are published in the ANSI (American National Standards Institute) B11 series. The following is a list of each ANSI B11 Standard available at the printing of this publication.

- B11.1 Mechanical Power Presses
- B11.2 Hydraulic Power Presses
- B11.3 Power Press Brakes
- B11.4 Shears
- B11.5 Iron Workers
- B11.6 Manual Turning Machines (Lathes)
- B11.7 Cold Headers and Cold Formers
- B11.8 Milling, Drilling, and Boring Machines
- B11.9 Grinding Machines
- B11.10 Metal Sawing Machines
- B11.11 Gear and Spline Cutting Machines
- B11.12 Roll Forming and Roll Bending Machines
- B11.13 Automatic Screw/Bar and Chucking Machines
- B11.14 Coil Slitting Machines/Systems
- B11.15 Pipe, Tube and Shape Bending Machines
- B11.16 Metal Powder Compacting Presses (Withdrawn)
- B11.17 Horizontal Hydraulic Extrusion Presses
- B11.18 Coil Processing Systems
- B11.19 Performance Criteria for Safeguarding
- B11.20 Safety Requirements for Manufacturing Systems/Cells
- B11.21 Lasers
- B11.22 CNC Turning Machines
- B11.23 Machining Centers
- B11.24 Transfer Machines
- B11.TR1 Ergonomics
- B11.TR2 Mist Control
- B11.TR3 Risk Assessment
- R15.06 Robotic Safeguarding

These standards can be purchased by contacting:

American National Standards Institute
25 West 43rd Street
New York, New York 10036
Phone: (212) 642-4900
Fax: (212) 398-0023
www.ansi.org

OR

AMT—The Association for Manufacturing Technology
7901 Westpark Drive
McLean, Virginia 22102
Phone: (703) 893-2900
Toll-Free: 1-800-524-0475
Fax: (703) 893-1151
E-Mail: AMT@amtonline.org
www.amtonline.org

(Continued on next page.)

NATIONAL SAFETY COUNCIL SAFETY MANUALS

Other good references for safety on machine tools are the National Safety Council's Safety Manuals. These manuals are written by various committees including the Power Press, Forging and Fabricating Executive Committee. Copies of the following publications are available from their library:

- Power Press Safety Manual - 5th Edition
- Safeguarding Concepts Illustrated - 7th Edition
- Forging Safety Manual

These manuals can be obtained by contacting:

National Safety Council
1121 Spring Lake Drive
Itasca, IL 60143-3201
1-800-621-7619 ext. 2199
Fax: (630) 285-0797
www.nsc.org

OTHER SAFETY SOURCES

National Institute of Occupational Safety and Health (NIOSH)
4676 Columbia Parkway
Cincinnati, OH 45226
Toll-Free: 1-800-35-NIOSH (1-800-356-4674)
Phone: (513) 533-8328
Fax: (513) 533-8573
www.cdc.gov/niosh

Warranty

9. Limited Warranties.

9.1. (i) Subject to Section 8.1(ii) below, Rockford Systems makes to Customer the following sole and exclusive warranties with respect to Goods:

(a) with respect to Goods that are manufactured based on Customer specifications, at the time of shipment by Rockford Systems, the Goods sold under the Agreement that are manufactured by Rockford Systems pursuant to such specifications conform to such specifications set forth in the applicable Order Documentation; and

(b) at the time of shipment by Rockford Systems, the Goods sold under the Agreement that are manufactured by Rockford Systems are free from defects in material and workmanship.

(c) Rockford Systems's warranty is for a period of 1 year, and begins from date of shipment from Rockford Systems to the original purchaser. This warranty does not include accessories, parts or equipment sold hereunder that are manufactured by someone other than Rockford Systems.

(ii) Every claim by Customer against Rockford Systems for breach of warranty with respect to the Goods shall be deemed waived by Customer unless written notice thereof is received by Rockford Systems within fifteen (15) days after discovery.

9.2. If Rockford Systems breaches either of the warranties set forth in Section 8.1(i) above, and written notice thereof is received by Rockford Systems from Customer within the applicable time period specified in Section 8.1(ii) above, Customer's sole and exclusive remedy and Rockford Systems's only obligation shall be, as Rockford Systems in its sole and exclusive judgment shall determine, the replacement of the nonconforming Goods, or an adjustment to the purchase price for the nonconforming Goods or the repair of the nonconforming Goods. All transportation charges related to replacement or repair of Goods shipped to Rockford Systems's plant or facility (or other place at Rockford Systems's direction) shall be prepaid by Customer. Rockford Systems shall be responsible for reasonable transportation charges back to Customer for Goods that have been replaced or repaired by Rockford Systems. Any replacement Goods or repaired Goods shall be subject to these Terms and Conditions.

OTHER SAFETY SOURCES (continued)

Robotic Industries Association (RIA)
900 Victors Way, Suite 140
P.O. Box 3724
Ann Arbor, MI 48106
Phone: (734) 994-6088
Fax: (734) 994-3338
www.roboticonline.com

NEMA (National Electrical Manufacturers Association)
1300 North 17th Street, Suite 1847
Rosslyn, VA 22209
Phone: (703) 841-3200
Fax: (703) 841-5900
www.nema.org

NFPA (National Fire Protection Association)
1 Batterymarch Park
Quincy, MA 02269-9101
Phone: (617) 770-3000
Fax: (617) 770-0700
www.nfpa.org

For additional safety information and assistance in devising, implementing or revising your safety program, please contact the machine manufacturer, your state and local safety councils, insurance carriers, national trade associations and your state's occupational safety and health administration.

9.3. THE EXPRESS WARRANTIES SET FORTH HEREIN ARE THE ONLY WARRANTIES APPLICABLE TO THE SALE OF GOODS BY ROCKFORD SYSTEMS TO CUSTOMER PURSUANT TO THE AGREEMENT, AND THEY EXCLUDE ALL OTHER EXPRESS, ORAL OR WRITTEN WARRANTIES, AS WELL AS ANY WARRANTIES IMPLIED BY LAW WITH RESPECT TO THE GOODS, INCLUDING WARRANTIES OF MERCHANTABILITY OR FITNESS FOR A PURPOSE, NOTWITHSTANDING ANY DISCLOSURE TO ROCKFORD SYSTEMS OF THE INTENDED USE OF THE GOODS.

9.4. Rockford Systems's warranties under Section 8.1(i) are void if repairs or modifications of the Goods are made by anyone other than Rockford Systems. Without limitation of the foregoing, Rockford Systems assumes no responsibility for and shall have no obligations to Customer because defects in any materials furnished by, or any faulty workmanship provided by, any party other than Rockford Systems.

9.5. Rockford Systems reserves the right to improve its products through changes in design or material without being obligated to incorporate such changes into products of prior manufacture. Customer cannot rely on any such changes as proof of insufficiency or inadequacy of prior designs of the Goods or material contained in the Goods.

9.6. If Customer grants to an end user of the Goods (or any other customer of Customer) any warranty that is greater in scope or time than the warranty and claims period stated herein, Rockford Systems shall not be liable beyond the scope of the limited warranty, the claim period, the damages and the remedies provided for under this Section.

9.7. Solely to the extent transferable, Rockford Systems assigns and transfers to Customer the original manufacturer's warranty on Goods sold hereunder that are not manufactured by Rockford Systems.

SECTION 2—INTRODUCTION

SSC1500 Part-Revolution Solid-State Control

SSC1500 Press Brake Control—Connection Diagram

NOTE: This connection diagram is a convenient reference that shows some of the typical connections to the module; it should not be used for reference during installation. Please refer to the enclosed wiring schematics when installing the control system.

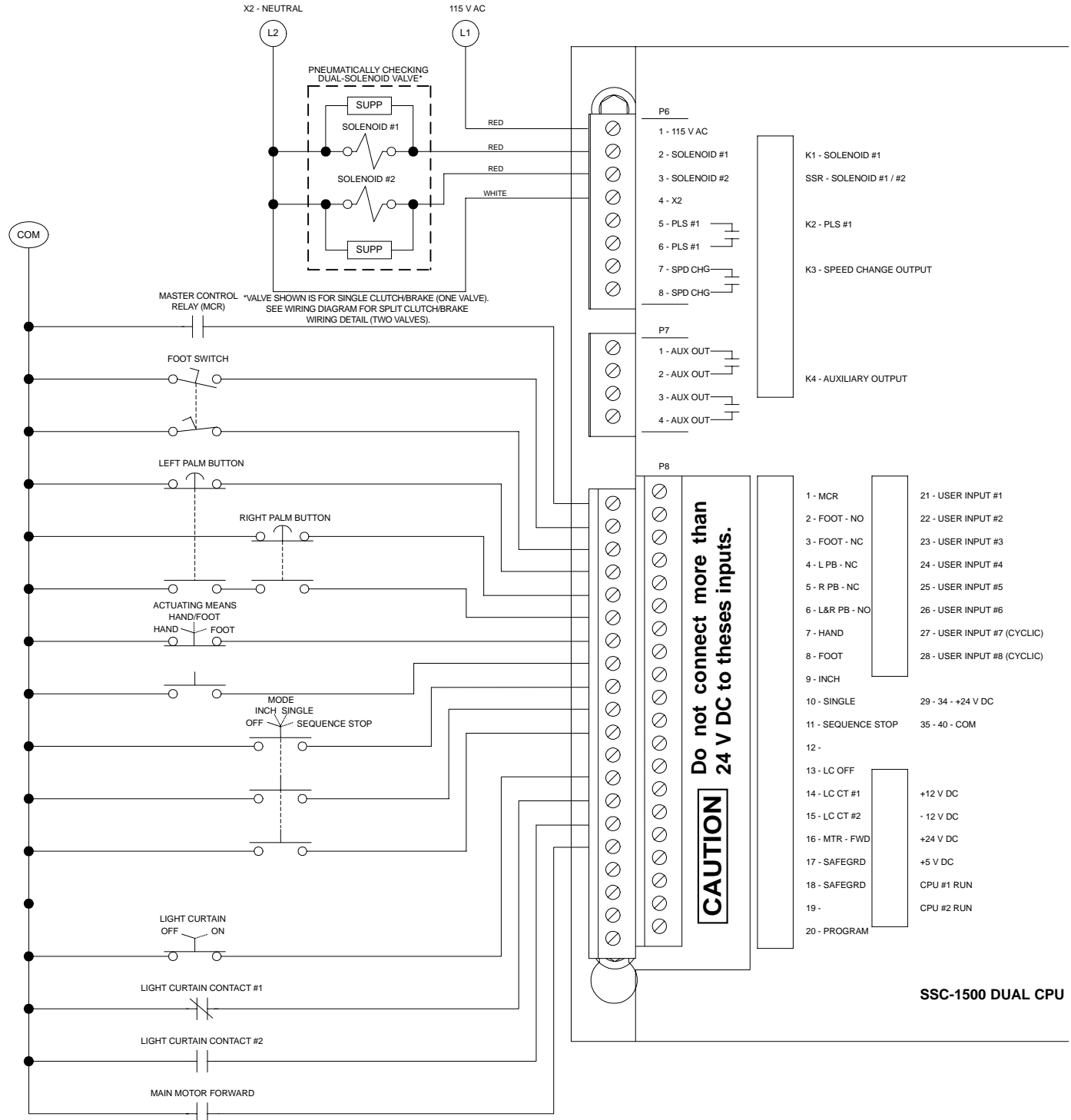

SECTION 2—INTRODUCTION

SSC1500 Part-Revolution Solid-State Control

Wiring When Optional Crankshaft Angle Display Is Furnished

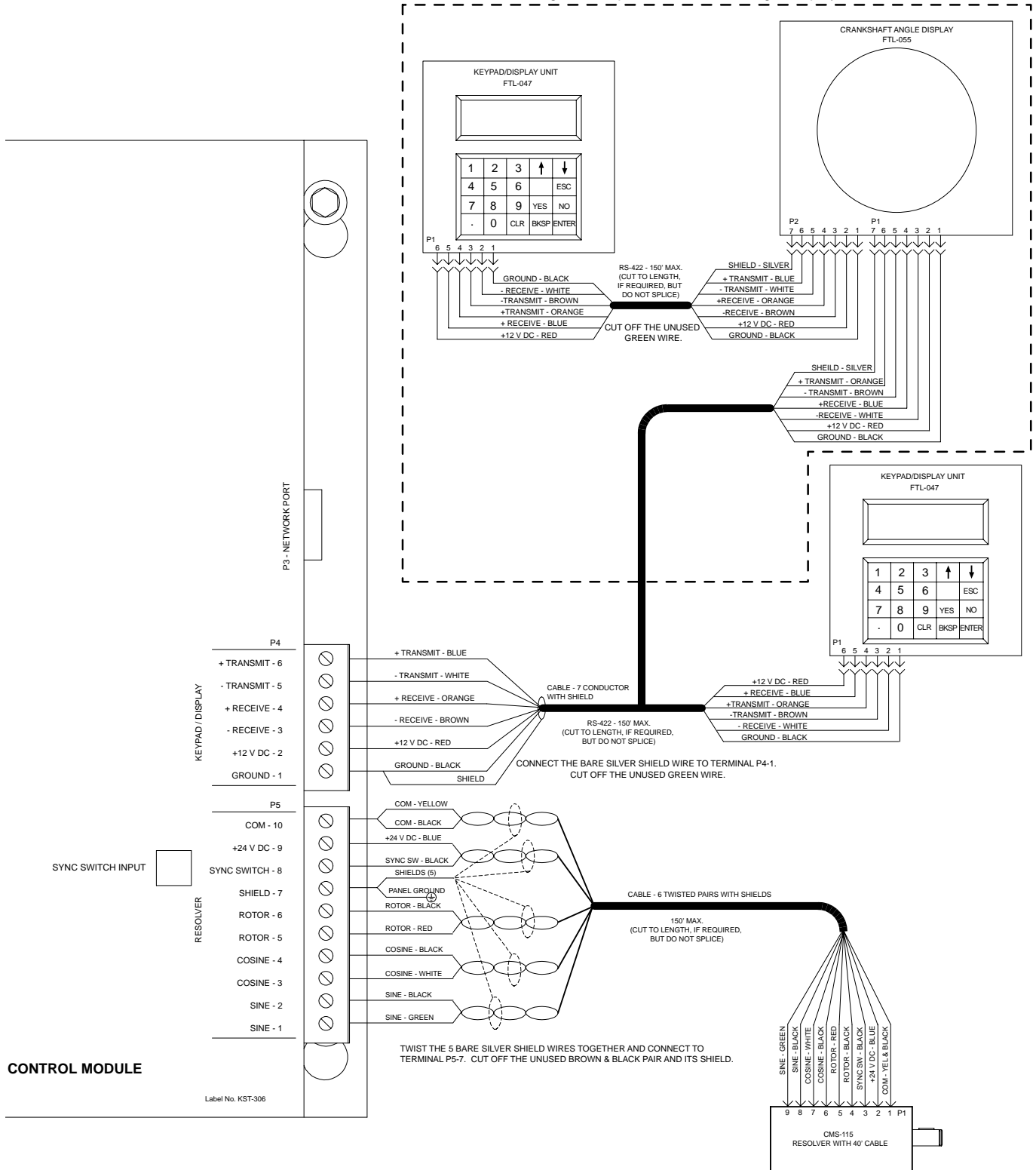

SECTION 2—INTRODUCTION

SSC1500 Part-Revolution Solid-State Control

General Description of Components in the System

A complete control package for part-revolution-clutch machines includes the following:

1. Literature folder (see pages 14-16) containing installation manuals, Operator Safety Precautions sign, danger sign(s), and electrical control schematics
2. Control box—a standard (custom or special may include motor controls and/or disconnect switch) with danger and warning signs attached
3. Monitored dual-solenoid air valve
4. Filter-regulator-lubricator (FRL) assembly including connector and mounting bracket
5. Air pressure switch (two required if machine has air counterbalance)
6. Check valve for counterbalance system (if required)
7. Air cylinder (for mechanical-friction-clutch press brakes only)
8. Resolver/pulser assembly, spring base, and 40' cable
9. Sprocket set to drive resolver/pulser assembly
10. Chain (10 feet with master link)
11. Palm button assembly (Includes two black palm buttons, two palm button guards, one red emergency-stop button, and mounting boxes) If multiple operator stations are on a machine, more than one assembly is furnished.)
12. Foot switch (optional)—If multiple operator stations are on a machine, more than one foot switch is furnished.
13. Supervisory control station (Required when multiple operator stations are used on the machine; one station is required for each operator.)
14. Multiple-operator junction box (When multiple operator stations are required, this junction box is furnished separately for wiring up to four operator stations.)
15. Other required components and safeguarding that may be necessary for the machine (See packing list for details.)

Individual packages may vary in contents. However, a packing list is always enclosed showing exactly what material was shipped on this order. Please check the components actually received against this packing list immediately. In most cases, this control package system includes two-hand control which can be used as a point-of-operation safeguarding device provided the palm buttons are mounted correctly and at the proper safety distance (see formula on page 32 of this manual). If the optional foot switch is provided, a safeguard must always be used. Examples of safeguards include barrier guards, presence-sensing devices, pullbacks, restraints, gates, or two-hand control. The hands or any other part of the body of an operator, maintenance person, setup person, etc., must never be put into the point-of-operation hazard for any reason, at any time.



This control can neither cure nor overcome a malfunctioning machine. It cannot compensate for or prevent a mechanical defect or failure of a machine part. This control cannot prevent a repeat or unintended stroke (cycle) resulting from a mechanical malfunction, defect or failure of the machine itself.

Preliminary Steps Before Installation

Before proceeding with the installation of the enclosed equipment, you should undertake the following preliminary steps.

1. Read and make sure you understand this entire installation manual.
2. Refer to the front cover, other line drawings and photos, then make a sketch of your installation to plan the location of the enclosed equipment on the machine.
3. This may be an opportunity to strip down the entire machine by removing all components, piping, wire, etc. Clean, paint and check the entire mechanical condition of the machine, including the clutch and brake, for proper adjustment and required replacement parts before proceeding with the installation of the furnished equipment.

(Continued on next page.)

Preliminary Steps Before Installation (continued)

- 4. Please make sure the machine is in first-class condition.** Before starting any installation, it is essential that the machine is thoroughly inspected. Be sure all mechanical components and all collateral equipment are in first-class operating condition. Your inspection should be done according to the machine manufacturer's installation and maintenance instruction manual. Special attention must be given to the machine clutch and brake. The clutch and brake must be maintained in an operating condition which is within the specifications set by the machine manufacturer. If you have any doubts or questions concerning the condition of the machine, contact the machine manufacturer for assistance. **Repair or replace all parts not operating properly before proceeding.**



Inspection and maintenance programs must be established and implemented to keep machines in first-class condition. Safety programs must include thorough inspections of each machine on a weekly basis and records kept of these inspections. Any part of the machine that is worn, damaged or is not operating properly must be replaced immediately or repaired before the machine is used.

- 5.** Verify that the machine is in first-class condition and operating properly; shut off all power to the machine. Padlock all electrical and pneumatic energy in the off position and do not actuate the machine again until the installation of all package components has been completed. Lockout/tagout energy isolation procedures must always be practiced and enforced.
- 6.** If the machine has a mechanical-friction clutch, an air cylinder is required to engage and disengage the clutch. Install the air cylinder in the most logical place to actuate the clutch. Please see the enclosed Installation Manual No. KSL-096 if an air cylinder was ordered. *Note: On machines equipped with air-operated friction clutches, an air cylinder is not required.*

Safeguard Interlocks and Other Types of Interlocks

SAFEGUARD INTERLOCKS

The machine will not operate or must not be operated until you either: (1) electrically interlock or (2) mechanically safeguard the machine's point of operation with a guard or device.

When an electrically interlocked method of safeguarding the point of operation is chosen, connect the interlock to the **safeguard interlock** terminals (P8-17 and P8-18) in the control box, and as shown on the control wiring schematic (wire numbers 86 and 87). If a light curtain(s) is used as the point-of-operation safeguard, it does not need to be interlocked in to P8-17 and P8-18 safeguard interlock terminals. Refer to the control wiring schematic for proper terminal connection of the light curtain.

Point-of-operation electrically interlocked safeguards, when opened, prevent or stop normal machine operation during operator cycling modes. Examples of these types of interlocks are barrier guard interlocks and gate device interlocks.

When a mechanical guard or device (nonelectrically interlocked) is chosen, the safeguard interlock terminals (P8-17 and P8-18) are not used. In order for the machine to operate with the use of a mechanical guard or device, the safeguard interlock terminals must be connected. Please see the wiring schematic.



The mechanical guard or device must be properly installed, used and maintained and must always prevent all personnel from bodily injury.



If the mechanical guard or device is not used, is removed, or is defeated, an electrically interlocked method of safeguarding must be used and connected to the safeguard interlock terminals (P8-17 and P8-18).



Never operate this machine without point-of-operation safeguarding.

SECTION 2—INTRODUCTION

SSC1500 Part-Revolution Solid-State Control

OTHER ELECTRICAL INTERLOCKS

There are basically two types of electrical interlocks as applied to machine control circuitry:

- Interlocks for the purpose of personnel protection, as explained on page 9.
- Interlocks intended for the purpose of protecting the machine and its control components.

There are other locations for interlocks that, when opened, prevent all machine functions. Examples of these types of interlocks are safety block electrical cut-off systems, lubricating systems, die protection equipment, and tonnage monitoring systems.

Be sure to connect the various electrical interlocks to the proper terminals, in the control box, according to the machine wiring schematics. If your schematics do not include these electrical interlocks, please send this information to the factory and they can be added to your drawings. There is an additional charge for this service.

General Features of the SSC1500 Control

- Redundant/Cross-Checking Microprocessors
- Redundant Microprocessor Logic Power Supplies
- Triple-Redundant Solid-State Solenoid Relays
- 4-Line x 20-Character LCD (Liquid Crystal Display) With 20-Key Keypad
- Absolute Resolver/Pulser With Sync Sensor for Timing and Motion Detection
- Wide Range of Input Power Supply—85 to 135 V AC
- Time-Based Brake Monitor With Programmable Warning and Fault Setpoints
- 6 User-Programmable 24-V DC Static Diagnostic or Die Protection Inputs
- 2 User-Programmable 24-V DC Cyclic Die Protection Inputs
- 7-Digit Total Counter, 7-Digit Batch Counter With Preset, and 7-Digit Stroke Counter With Preset
- Light Curtain(s) Interface With Off/On Selector Switch
- 1 PLS (Programmable Limit Switch) Output—On/Off Angle, Timed Off, or Counted Output
- 1 Auxiliary Output With 2 Contacts
- Information Displayed When the Machine Is in Operation—Angle, Speed, Batch Counter, Stroke Counter, Mode of Operation, and Stop Time
- Display of Text in English or Spanish

MODES OF OPERATION

- Off
- Two-Hand Inch (Regular, Timed, or Top-Stop)
- Two-Hand Single Stroke
- Foot Single Stroke
- Sequence Stop (Hand/Hand—Hand/Foot—Foot/Foot)
- High/Low Automatic Speed Change (for Two-Speed Only)

Overview of Motion and Settings

The redundant inputs are used by both processors to control the operation of the press brake. When the actuating means are depressed, and the primary safeguard interlock conditions are met, the processors turn on their appropriate relays (SSR1 and SSR2). The dual-solenoid valve is energized sending air to the air cylinder or clutch and brake. The crankshaft is engaged to the flywheel drive and the brake is released allowing the ram to move. Within the motion reference time window, the microprocessors must see a voltage signal from the DC tachometer in the resolver/pulser assembly that represents motion or a motion fault is generated. If the actuating means are released prior to the auto up (holding) angle, the slide movement will stop. The stroke can be finished by depressing the actuating means again.

For brake monitoring, the control starts a timer when the relays and solenoids are de-energized. This timer stops when the motion from the tachometer in the resolver/pulser has stopped. The stop-time value is then compared to the brake stop-time setpoint. If the stop time exceeds this setting, a brake fault message is displayed. The reason for the increased stop time should be investigated and corrected before operating the machine again. (See pages 50-52 for programming the brake monitor.)

Sequence of Operation

This sequence of operation applies to all standard modes provided with the SSC1500 press brake control.

OFF

The press brake is inoperable in this mode of operation. The **OFF** position cannot be used solely as the lockout/tagout means. To use any of the following modes of operation, turn the mode selector switch from **OFF** to the appropriate position.

Two-Hand Inch is a mode of operation in which the ram travels as long as the operator(s) maintains actuation of the palm buttons. Each time the buttons are released, the ram will stop.

If *Timed Inch* is turned on, the clutch will engage and the ram will move only for a set amount of time programmed in to the control, even if the palm buttons are held depressed. See page 67 of this installation manual for *Timed Inch* programming information.

To use *Two-Hand Inch*, the mode selector switch must be set to **INCH**, and the actuating means selector switch must be set to **HAND**.

Top-Stop Inch is similar to normal *Inch*. If *Top-Stop Inch* is turned on, the slide will stop at top every cycle, even if the palm buttons are held depressed. See page 68 of this installation manual for *Top-Stop Inch* programming.



The *Inch* mode of operation is used for die setup, tool setup, and maintenance only. It is not intended for use during production operations.

TWO-HAND SINGLE STROKE

Two-Hand Single Stroke is a mode of operation in which the slide makes one complete stroke or cycle upon actuation of the palm buttons. The palm buttons must be held depressed until the programmed automatic up (holding) angle is reached. If they are released before this angle is reached, the slide will stop and the buttons will need to be released and then reactivated. The automatic up (holding) angle should be programmed so that the palm buttons are held depressed during the entire die-closing portion of the stroke. Once the slide passes the automatic up (holding) angle, the palm buttons can be released and the slide will automatically return to the top.

To use *Two-Hand Single Stroke*, the mode selector switch must be set to **SINGLE**, and the actuating means selector switch must be set to **HAND**.

(Continued on next page.)

SECTION 2—INTRODUCTION

SSC1500 Part-Revolution Solid-State Control

FOOT SINGLE STROKE

Foot Single Stroke is a mode of operation in which the ram makes one complete stroke or cycle upon actuation of the foot switch. The foot switch must be held depressed until the programmed automatic up (holding) angle is reached. If it is released before this angle is reached, the ram will stop and it will need to be released and then reactuated. Once the ram passes the automatic up (holding) angle, the foot switch can be released and the ram will automatically return to the top.

To use *Foot Single Stroke*, the mode selector switch must be set to **SINGLE**, and the actuating means selector switch must be set to **FOOT**.



A point-of-operation safeguard must be used when using this mode of operation.

HAND/HAND SEQUENCE STOP

Hand/Hand Sequence Stop is a mode of operation in which the palm buttons are held depressed until the slide automatically stops at the programmed sequence stop point (usually $\frac{1}{4}$ " above the workpiece). If the palm buttons are released during this portion of the stroke, the slide will stop and the buttons will need to be released and then reactuated. Once the sequence stop point is reached, the palm buttons must be released, and the operator can position the workpiece or make sure it is in place. The palm buttons must then be reactuated to finish the stroke. After the sequence stop point, the slide can either be inched through the bottom of the stroke, or it can automatically return to the top, depending on where the programmed automatic up (holding) angle is set.

To use *Hand/Hand Sequence Stop*, the mode selector switch must be set to **SEQ STOP**, and the actuating means selector switch must be set to **HAND**.

HAND/FOOT SEQUENCE STOP

Hand/Foot Sequence Stop is a mode of operation in which the palm buttons are held depressed until the slide automatically stops at the programmed sequence stop point (usually $\frac{1}{4}$ " above the workpiece). If the palm buttons are released during this portion of the stroke, the slide will stop and the buttons will need to be released and then reactuated. Once the sequence stop point is reached, the palm buttons must be released, and the operator can position the workpiece or support it in place. The foot switch must then be actuated to finish the stroke. After the sequence stop point, the slide can either be inched through the bottom of the stroke, or it can automatically return to the top, depending on where the programmed automatic up (holding) angle is set.

To use *Hand/Foot Sequence Stop*, the mode selector switch must be set to **SEQ STOP**, and the actuating means selector switch must be set to **HAND/FOOT**.

FOOT/FOOT SEQUENCE STOP

Foot/Foot Sequence Stop is a mode of operation in which the foot switch is held depressed until the slide automatically stops at the programmed sequence stop point (usually $\frac{1}{4}$ " above the workpiece). If the foot switch is released during this portion of the stroke, the slide will stop and the foot switch will need to be released and then reactuated. Once the sequence stop point is reached, the foot switch must be released, and the operator can position the workpiece or support it in place. The foot switch must then be reactuated to finish the stroke. After the sequence stop point, the slide can either be inched through the bottom of the stroke, or it can automatically return to the top, depending on where the programmed automatic up (holding) angle is set.

To use *Foot/Foot Sequence Stop*, the mode selector switch must be set to **SEQ STOP**, and the actuating means selector switch must be set to **FOOT**.



A point-of-operation safeguard must be used when using this mode of operation.

(Continued on next page.)

NOTE: The following feature can only be used with two-speed air-clutch press brakes.

HIGH/LOW SPEED CHANGE

High/Low Speed Change is a feature in which the slide switches from high to low speed at the programmed speed change on angle (usually $\frac{1}{4}$ " above the workpiece). This reduces whip-up action and allows more control when forming the part. The slide continues in low speed until the programmed speed change off angle is reached (usually at the bottom of the stroke or slightly after), and then it returns to the top of the stroke in high speed.

To use *High/Low Speed Change*, the mode selector switch can be in any position, and the speed selector switch must be set to **HIGH/LOW**.

OPTIONAL MODES

Top-Stop Inch and *Inch With Fault* are optional modes of operation also provided with the SSC-1500 press brake control. These modes of operation are accessed through the optional modes program screen. See page 68 of this installation manual for programming information.



A point-of-operation safeguard must be used when using any of these modes of operation.

SECTION 3—INSTALLATION OF COMPONENTS

SSC1500 Part-Revolution Solid-State Control

Introduction

The following additional materials are required to install the equipment in this shipment.

1. Wire: Size and type will depend on local ordinances or plant practices. We recommend stranded machine tool wire with appropriate color-coding. **Never use solid wire**—the vibration caused by these machines precludes the successful use of solid wire for these installations.
2. Numbered wire markers: Made of suitable material to resist oil, grease, etc., and remain firmly attached to the wire.
3. Conduit: Rigid, liquid-tight flexible, or any other suitable tubular connecting means which complies with local ordinances and provides adequate mechanical protection for the wires. Most of the electrical products supplied have an oil-tight construction.
4. Miscellaneous wiring components such as electrical tape, wire connectors, and terminals, as required.

ILLUSTRATION OF ELECTRICAL SYSTEM ON PART-REVOLUTION-CLUTCH POWER PRESS BRAKE

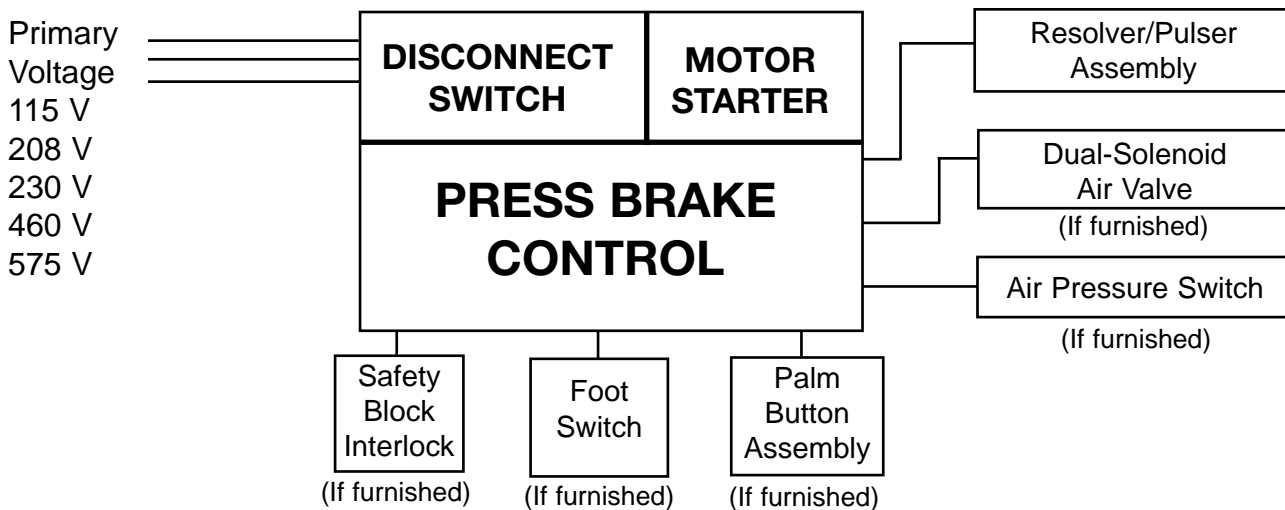

LITERATURE FOLDER

Included with every shipment is a literature folder. This includes installation manuals, Operator Safety Precautions sign (Part No. KSC000), danger signs, and electrical schematics. These publications must be available and fully understood by all appropriate personnel, before any retrofit installation begins. Please notify Rockford Systems immediately if there are any questions about the components received.

(Continued on next page.)

SECTION 3—INSTALLATION OF COMPONENTS

SSC1500 Part-Revolution Solid-State Control

OPERATOR SAFETY PRECAUTIONS SIGN

Photo 3.1 - Part No. KSC000 Operator Safety Precautions Sign

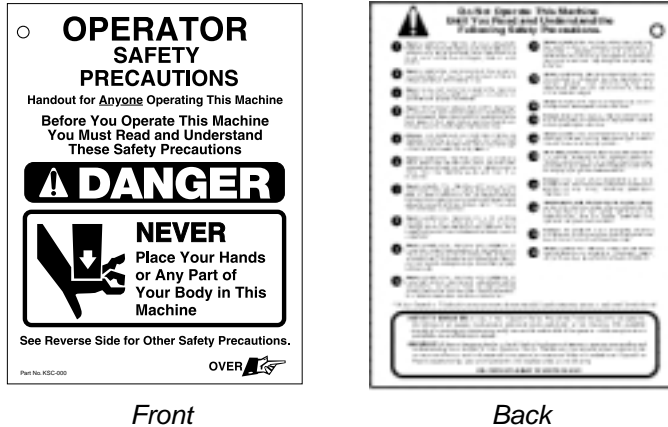

Front

Back

Photo 3.2



Photo 3.3



Photo 3.4



Attachment of Precautions Sign

1. Locate the Operator Safety Precautions sign.
2. Attach the sign to the machine with a nylon tie through the hole provided. See Photo 3.2.



Attach it to the machine where it is readily accessible and visible to the operator. Additional copies of these precautions are available. Please call, write, fax, e-mail or use the order form found on a later page in this manual.



When a language barrier or insufficient education prevents a person from reading or understanding the contents of this sign, you should either translate this information or have it read or interpreted to the person. Make sure the person understands the information. To order this sign in Spanish, use Part No. KSC000S; in French, use Part No. KSC000F.



These precautions must be reviewed daily.

DANGER SIGNS

1. Locate the furnished danger signs.
2. Determine the mounting location for the danger signs on the machine.



They must be permanently mounted in a prominent location on the machine where they are readily accessible and visible to the operator, setup person, or other personnel who work on or around this machine.

3. Drill a hole(s) in the sign and the machine at the mounting location. See Photo 3.3.
4. Attach the signs to the machine with screws or rivets. See Photo 3.4.



Never operate this machine unless the danger signs are in place. Also make sure the signs are read and understood before operating the machine.

SECTION 3—INSTALLATION OF COMPONENTS

SSC1500 Part-Revolution Solid-State Control

Figure 3.1 - Illustration of the Placement of the Operator Safety Precautions Sign and Danger Signs

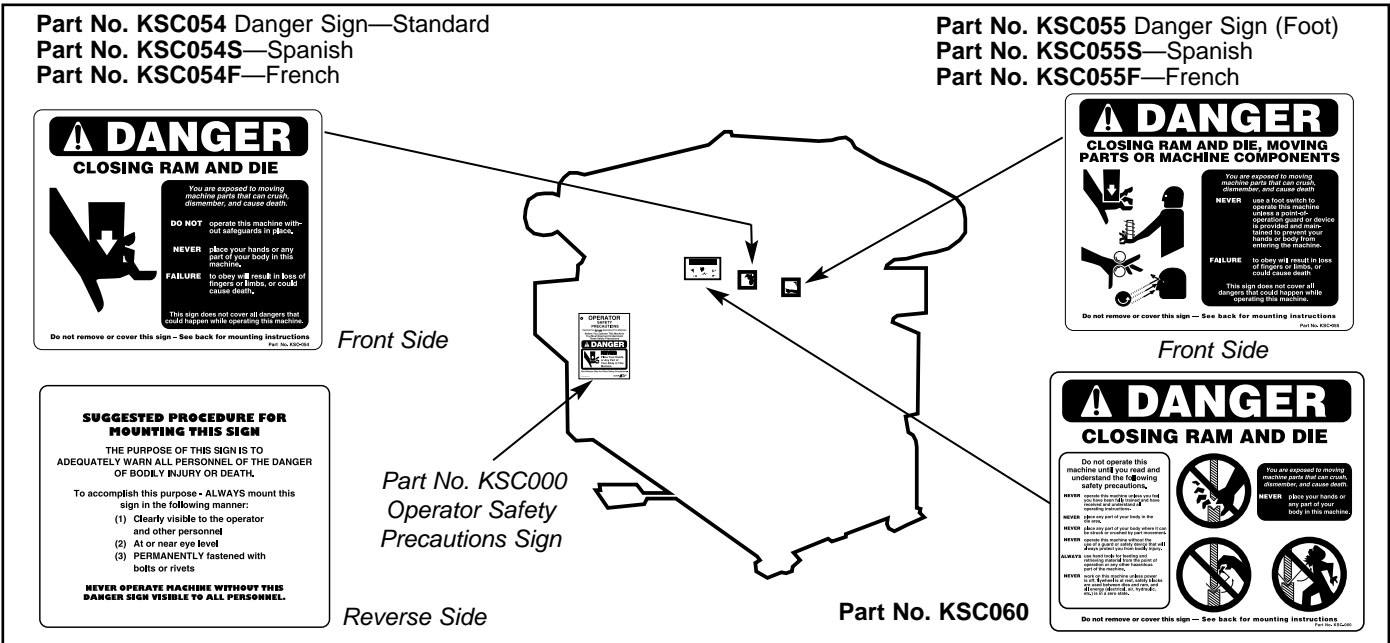

Control Box

DANGER AND WARNING LABELS PROVIDED

The illustrated danger and warning labels are affixed to all control boxes provided. All personnel operating or working around the machine, where this control box is installed, must be required to read, understand and adhere to all dangers and warnings. If any of these labels become destroyed or unreadable, they MUST be replaced. Contact the factory immediately for replacement labels and do not operate the equipment until danger and warning labels are all in place.

Photo 3.5
 SSC1500 Standard
 Control Box Outside View



SECTION 3—INSTALLATION OF COMPONENTS

SSC1500 Part-Revolution Solid-State Control

Control Box (continued)

The SSC1500 is an economic, full-featured, dual-microprocessor-based control for part-revolution-clutch mechanical power press brakes. This control system is designed to comply with **OSHA 29 CFR 1910.212 and ANSI B11.3**. It is a replacement for existing relay-based control systems, found in users' plants, or can be furnished for new or rebuilt press brakes.

This control can be supplied in a custom box with a motor starter(s) and a disconnect, or as a standard control to interface with existing press motor controls. Enclosure systems for the control include a standard 20" x 20" x 8" box with the keypad/display mounted on the door of the enclosure. A plain-door enclosure with the keypad/display mounted in a remote operator station may have been furnished.

When the control box is wired to an existing main motor starter, the starter must have a 120-V coil and in most cases, an auxiliary contact. If the starter does not have these components and they are not readily available, please contact Rockford Systems for a replacement magnetic motor starter.

The system uses redundant inputs from devices such as palm buttons, foot switches, and light curtain(s). The system output to the dual-solenoid air valve is provided by one safety relay with force-guided contacts and two solid-state relays. These output relays are independently controlled and cross-checked by the microprocessors. This allows control-reliable operation of the outputs in the event of a single control component failure. Each microprocessor also has its own logic power supply. This decreases the possibility of simultaneous control failure because of a fault within the power supply system. All the inputs are optically isolated for electrical noise immunity. Timing and motion detection of the crankshaft is provided by the resolver/pulsar assembly. The operator provides setup information through the use of the keypad/display and messages are shown on the 4-line x 20-character LCD.



Photo 3.6
Suppressors, ferrules,
and extra fuses are
furnished with each
control.

This solid-state control operates at a low voltage. Any component such as the dual valve or anything the control will operate (i.e., relay, solenoids) that is at a higher voltage (115 V) must be suppressed. Three (3) suppressors are furnished with all control boxes. Make sure they are installed on the solenoid contacts to filter out electrical noise that could affect the operation of the control.

Two extra fuses are also furnished with all control boxes. Use the corresponding replacement fuse if the original fuse should blow on the printed circuit board (fuses F1 through F6—see page 21), or to replace a blown fuse inside the off/on switch on the side of the control module (see Photo 3.7).

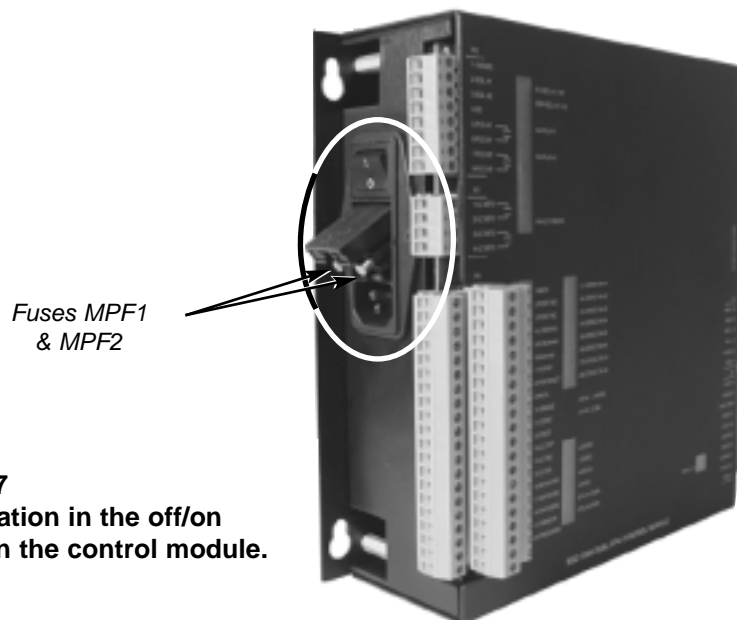

Photo 3.7
Fuse location in the off/on
switch on the control module.

SECTION 3—INSTALLATION OF COMPONENTS

SSC1500 Part-Revolution Solid-State Control

STANDARD CONTROL BOX

The standard control box (20" x 20" x 8") is furnished with the keypad/display, program off/on selector switch, and other selector switches on the front of the enclosure door. This NEMA 12 enclosure contains the control module assembly, master control relay, primary multi-tap transformer, and terminal strips. A standard box with a plain door is also available for use with a remote operator station.



Photo 3.8
Standard
Control Box

Photo 3.9
Inside View of
Standard Control Box

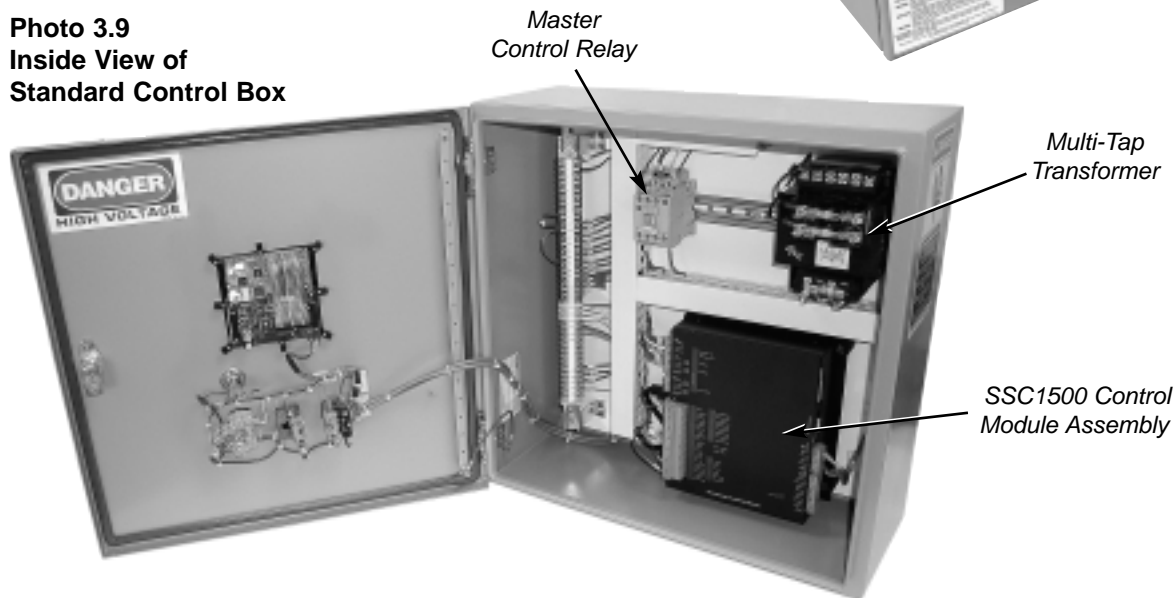

CUSTOM CONTROL BOX

A custom control box contains the standard control module and components described above plus the following:

- main power disconnect switch
- main drive motor starter
- ram-adjust motor starter (if furnished)

This NEMA 12 enclosure will vary in size based on the size of the disconnect switch and motor starter components. The enclosure contains the disconnect switch, main motor starter, ram-adjust motor starter (if furnished), clutch/brake control module, master control relay, primary multi-tap transformer, and terminal strips. The keypad/display, selector switches, motor controls, and disconnect switch handle may have been furnished on the door of the enclosure, or furnished as a plain-door enclosure for use with a remote operator station.



Photo 3.10
Plain-Door Custom Control Box with
Remote Operator Station

SECTION 3—INSTALLATION OF COMPONENTS

SSC1500 Part-Revolution Solid-State Control

REMOTE OPERATOR-STYLE CONTROL BOXES

Remote operator-style control boxes include the same features and modes of operation as the standard control box described on page 18. **However, they do not have a control transformer.** These controls are for applications where the machine's existing magnetic motor starter, fused disconnect switch, and **control transformer** meet the safety requirements and can be reused. If the existing control transformer cannot be reused or a new control transformer is required, contact the factory.

The three remote operator-style control boxes available have the keypad/display and all operators on the door of the 16" x 16" x 8" enclosure. The remote operator-style control boxes available are:

Style X—Standard SSC1500 control box without the control transformer

Style Y—Standard SSC1500 control box without the control transformer, but with an e-stop button in the enclosure

Style Z—Standard SSC1500 control box without the control transformer, but with an e-stop button, and two (2) guarded run/inch buttons on the sides of the enclosure



Photo 3.11
Style Z Remote
Operator Control Box



Photo 3.12

CONTROL MODULE KIT*

When a control module kit is furnished, it is supplied without the control enclosure, panel, control transformer, control fuse, terminal strips, wire duct, and wiring. This control module kit includes the control module, master control relay, shock mounts, fasteners, suppressors, extra fuses, ferrules, danger labels, and electrical prints. The minimum area required to install this kit on an existing control panel is 14" x 12" x 6". The electrical prints supplied with this kit show typical wiring and all dimensions.

KEYPAD/DISPLAY KIT* PART NO. LLD1519

When a keypad/display kit is furnished for use with any of the control boxes or control module kit, it includes the keypad/display, a screen label, a program off/on selector switch, a light curtain off/on selector switch, an actuating means selector switch, a mode selector switch, and 25' of cable. Additional push buttons and nameplates for motor starters, etc., may have been furnished depending on the features required. The area needed to mount the keypad/display kit is 10" x 6 $\frac{3}{4}$ " x 3".



Photo 3.13

***A certified electrician is required for the installation of a control module kit and keypad/display kit. If you do not have access to a certified electrician, please contact Rockford Systems at 1-800-922-7533, and we will propose the cost of having our installation team provide the installation.**

SECTION 3—INSTALLATION OF COMPONENTS

SSC1500 Part-Revolution Solid-State Control

CONTROL MODULE ASSEMBLY

The solid-state control module assembly below, Part No. FTL046, measures 8¼" W x 8¾" H x 3¾" D. It is mounted to the panel with four shock/vibration mounts and four ¼-20 x ½" Allen-head bolts. The module case has four keyhole mounting slots that allow for easy removal, without taking off the Allen-head mounting bolts.

Red and green LEDs allow for visual indication of control operation and the status of inputs and outputs. There are two green CPU (central processing unit) run indicator status lights. All LED names are indicated on the cover of the module next to each LED. See photo 3.14.

Photo 3.14
Top View of Control Module with Cover

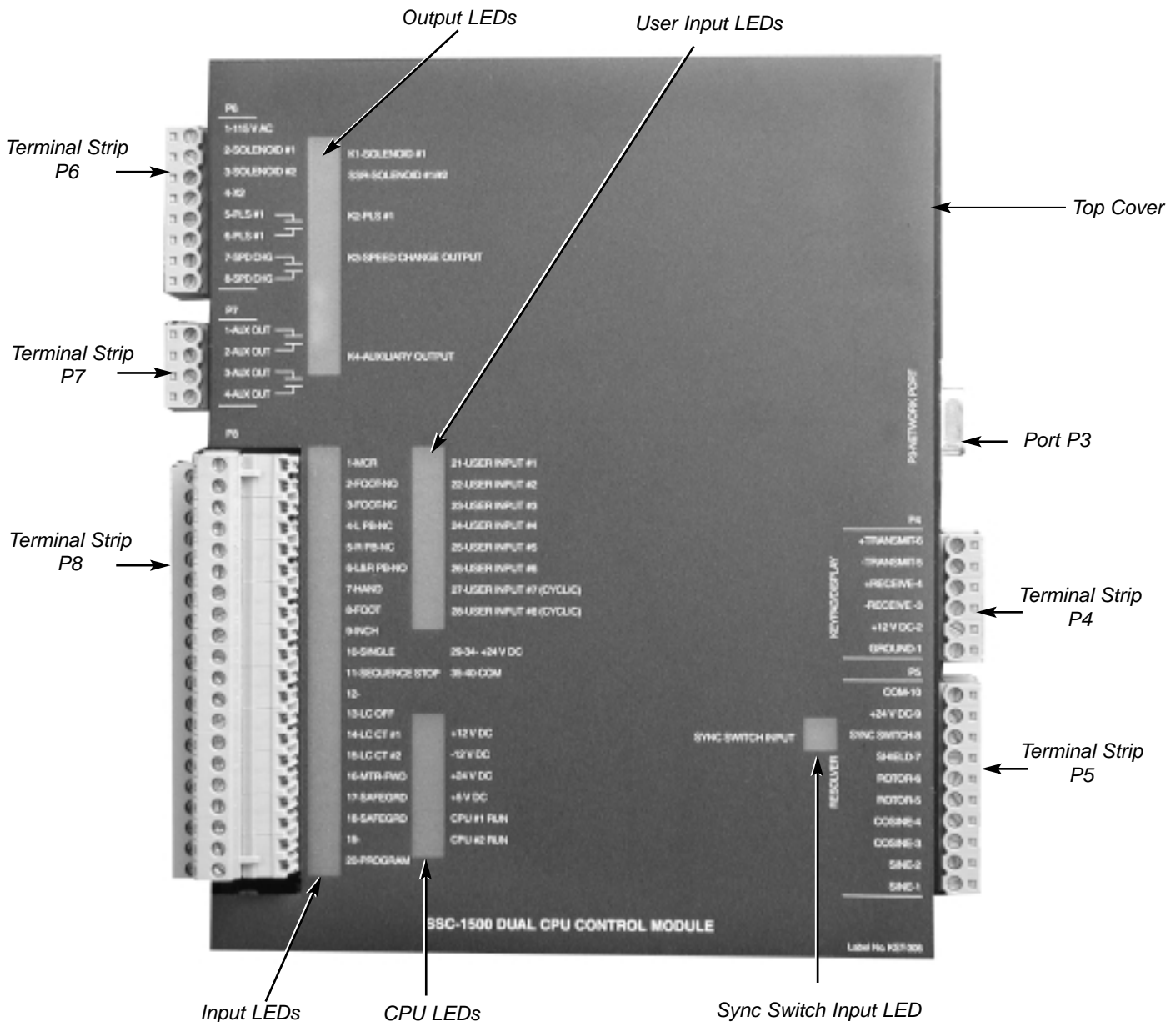

(Continued on next page.)

SECTION 3—INSTALLATION OF COMPONENTS

SSC1500 Part-Revolution Solid-State Control

CONTROL MODULE ASSEMBLY (continued)

If necessary, the cover of the module can be taken off by removing the screws on the corners and pulling the top straight off. The dual-CPU circuit board is then exposed as shown in the photo below.

Photo 3.15

Top View of Control Module without Cover

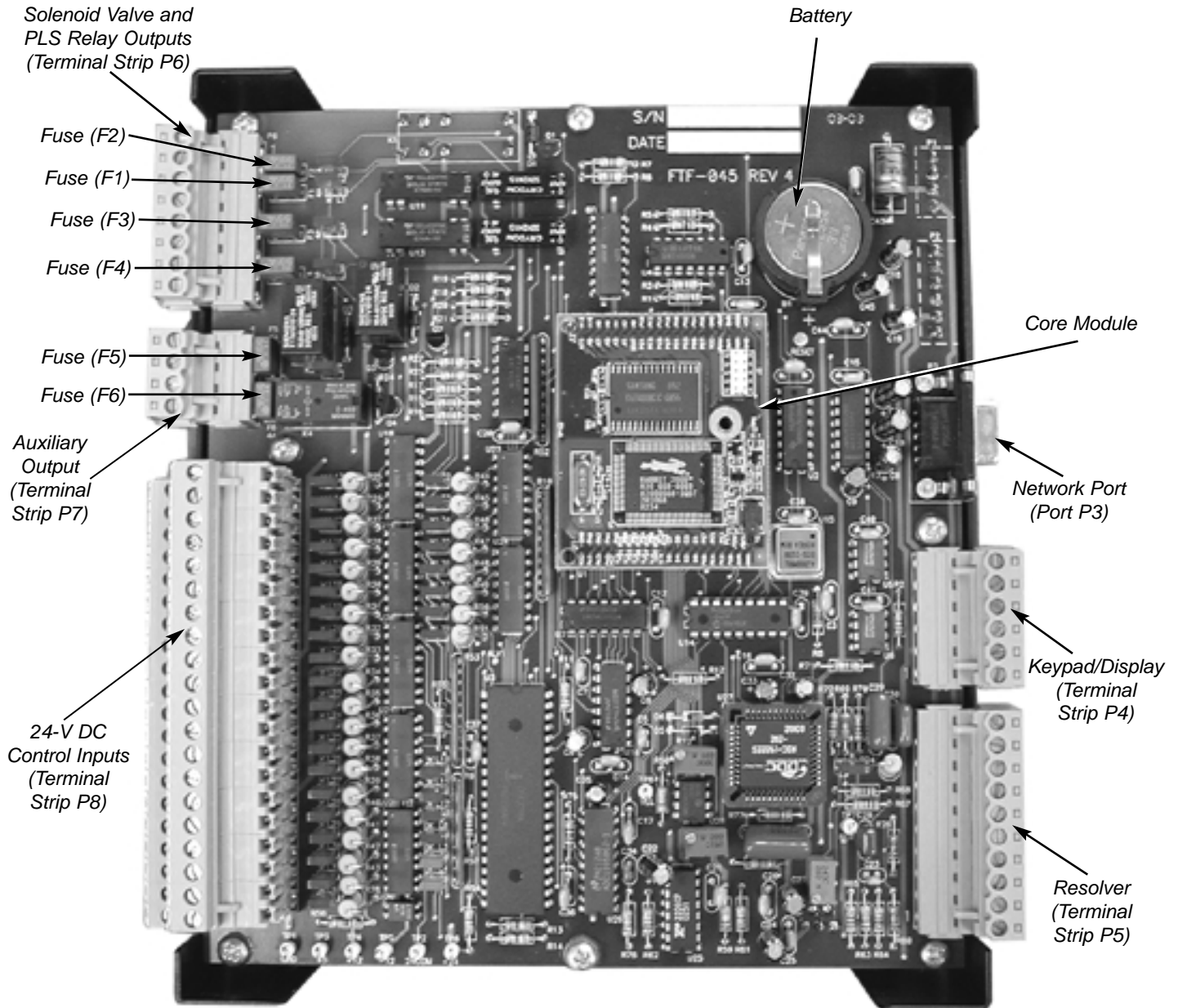

User-serviceable parts on the dual-CPU board are the core module, the battery, and the fuses. F1 and F2 fuses are for circuit protection of S1 and S2 (solenoids). F3 and F4 fuses are for circuit protection for K2 and K3. F5 and F6 fuses are for circuit protection of the auxiliary output relay. MPF1 and MPF2 fuses are the main power supply fuses (see photo 3.7 on page 17).

If any changes to the circuit boards are required, instructions will be sent with the new parts. See Section 8—Replacement Procedures for instructions on replacing the core module, fuses, and battery.

SECTION 3—INSTALLATION OF COMPONENTS

SSC1500 Part-Revolution Solid-State Control

Photo 3.16
Keypad/Display



KEYPAD/DISPLAY ASSEMBLY

The keypad/display assembly, Part No. FTL047 (Photo 3.16) is used to enter setup information and to monitor machine operation.

The keypad/display can be furnished in a remote enclosure up to a maximum of 150' from the SSC1500 control module. Information displayed during the machine run cycle are **Angle, Speed, Batch Counter, Stroke Counter, Mode, and Stop Time**. All programming is accessed by a program off/on keyed selector switch. See pages 43-73 of this manual for programming information.

Mounting the Control Box

Solidly mount the control box in an accessible location, either on or near the machine to be controlled. A convenient location will keep conduit runs to a minimum length.

Although operation of this control will not be adversely affected by normal machine operation, excessive shock or vibration may require shock mounting in specific applications, and some applications may require remote mounting of the control box (off the press brake). Special stands or mounting brackets may need to be fabricated to accommodate remote mounting.

CAUTION Do not run cable in conduit or in bundles with higher voltages that may cause electrical interference.

If your control has the keypad/display assembly mounted on the door of the enclosure, the keypad/display wires will already be ferruled and connected to Terminal Strip P4 on the SSC1500 control module. For all other controls, this will have to be done during installation.

Twenty-five feet of cable is supplied as standard (if the keypad/display is remote) and can be cut to length, if required. Do not splice the cable or interrupt the signals. If a longer cable is required, please contact the factory.

When connecting the keypad/display wires to Terminal Strip P4, please follow the wiring schematics included with the control and see Photo 3.17. Strip the wires and crimp the supplied ferrules on each wire.* Terminal Strip P4 has a color-coded number label. Match each wire with the appropriate terminal in accordance with the wiring schematics and the color-coding. Make sure each wire is tight and making good contact with the metal part of the ferrule.

The bare silver shield wire should be twisted and put in a larger ferrule with the black wire and connected to Terminal P4-1.

Note: There is a green wire in the keypad/display cable that is not used. Cut this wire off and discard it.

*A special crimping tool is required to properly crimp the ferrules on the wires. If you do not have one, it is available from:

Weidmuller Inc.
821 Southlake Boulevard
Richmond, Virginia 23236
Toll-Free: 1-800-849-9343
Phone: (804) 794-2877
Fax: (804) 794-0252
www.weidmuller.com

We use the Weidmuller Type PZ 3, Part No. 056730 crimping tool.

Photo 3.17—Terminal Strip P4 Wiring Connection on the SSC1500 Control Module

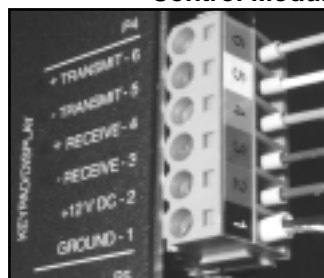

No. 6—Blue
No. 5—White
No. 4—Orange
No. 3—Brown
No. 2—Red
No. 1—Black and Bare Silver Shield
(together in larger ferrule)

SECTION 3—INSTALLATION OF COMPONENTS

SSC1500 Part-Revolution Solid-State Control

Photo 3.18—Crankshaft Angle Display

CRANKSHAFT ANGLE DISPLAY (OPTIONAL)

The crankshaft angle display, Part No. FTL055 (photo 3.18), is an optional unit that shows the angular position of the crankshaft both graphically (with red LEDs in a circle) and numerically (with a large, red, three-digit LED display). The angle display should be mounted where it is easily viewed to help with setup, removal of stuck workpieces, or for assistance during emergency extraction procedures.



CAUTION Do not run cable in conduit or in bundles with higher voltages that may cause electrical interference.

Two 25' cables are supplied as standard and can be cut to length, if required. Do not splice the cables or interrupt the signals. If longer cables are required, please contact the factory.

One of the cables connects between Terminal Strip P4 on the SSC1500 control module and Terminal Strip P1 on the crankshaft angle display. The other cable connects between Terminal Strip P2 on the crankshaft angle display and the keypad/display assembly.

When connecting Terminal Strip P1 on the crankshaft angle display wires to Terminal Strip P4 on the SSC1500 control module, please follow the wiring schematics included with the crankshaft angle display and see Photos 3.19 and 3.20. Strip the wires and crimp the supplied ferrules on each wire.* Terminal Strip P4 has a color-coded number label. Match each wire with the appropriate terminal in accordance with the wiring schematics and the color-coding. Make sure each wire is tight and is making good contact with the metal part of the ferrule. The bare silver shield wire should be twisted and put in a larger ferrule with the black wire and connected to Terminal P4-1.

Note: There is a green wire in the keypad/display cable that is not used. Cut this wire off and discard it.

Photo 3.19—Terminal Strip P4 Wiring Connection on the SSC1500 Control Module

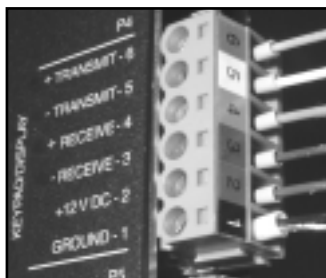

- No. 6—Blue
- No. 5—White
- No. 4—Orange
- No. 3—Brown
- No. 2—Red
- No. 1—Black and Bare Silver Shield (together in larger ferrule)

Photo 3.20—Terminal Strip P1 Wiring Connection on the Crankshaft Angle Display



- No. 1—Black
- No. 2—Red
- No. 3—White
- No. 4—Blue
- No. 5—Brown
- No. 6—Orange
- No. 7—Silver

*A special crimping tool is required to properly crimp the ferrules on the wires. If you do not have one, it is available from:

Weidmuller Inc.
821 Southlake Boulevard
Richmond, Virginia 23236
Toll-Free: 1-800-849-9343
Phone: (804) 794-2877
Fax: (804) 794-0252
www.weidmuller.com

We use the Weidmuller Type PZ 3, Part No. 056730 crimping tool.

(Continued on next page.)

SECTION 3—INSTALLATION OF COMPONENTS

SSC1500 Part-Revolution Solid-State Control

CRANKSHAFT ANGLE DISPLAY (continued)

When connecting Terminal Strip P2 on the crankshaft angle display wires to the keypad/display assembly, the existing cable that came with the control can be used; however, if this cable is too short, discard it and use the cable furnished with the crankshaft angle display. Please follow the wiring schematics included with the crankshaft angle display and see Photo 3.21. Strip the wires and crimp the supplied ferrules on each wire.* Match each wire with the appropriate terminal in accordance with the wiring schematics and the color-coding. Make sure each wire is tight and is making good contact with the metal part of the ferrule.

Note: There is a green wire in these cables that is not used. Cut this wire off and discard it.

Photo 3.21—Terminal Strip P2 Wiring Connection on the Crankshaft Angle Display

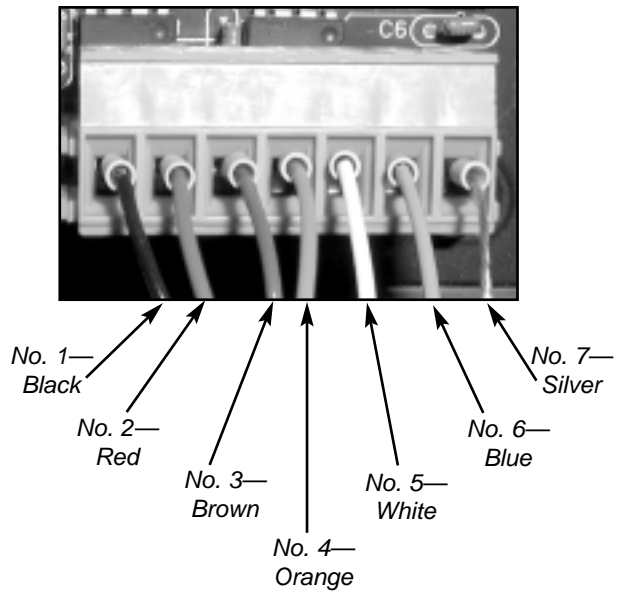

*A special crimping tool is required to properly crimp the ferrules on the wires. If you do not have one, it is available from:

Weidmuller Inc.
821 Southlake Boulevard
Richmond, Virginia 23236
Toll-Free: 1-800-849-9343
Phone: (804) 794-2877
Fax: (804) 794-0252
www.weidmuller.com

We use the Weidmuller Type PZ 3, Part No. 056730 crimping tool.

SECTION 3—INSTALLATION OF COMPONENTS

SSC1500 Part-Revolution Solid-State Control

Resolver/Pulser Assembly

The absolute resolver/pulser assembly with spring-tension base is used to provide position and velocity/motion information of the machine crankshaft to the control. The resolver is a highly accurate and repeatable timing device. The resolver/pulser is contained in a rugged, heavy-duty housing with a spring-tension base. The $\frac{3}{4}$ " diameter steel shaft is mounted in sealed ball bearings. This results in a rugged transducer assembly for press applications. The resolver/pulser is furnished with a 40' cable that attaches to the drive assembly and wires in to the control box. When installing, the cable can be cut to the exact length required (do not splice). For more than 40' of cable, please contact factory. See the next page or the enclosed wiring schematics for proper wiring.

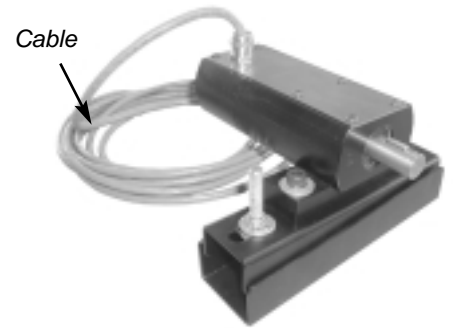
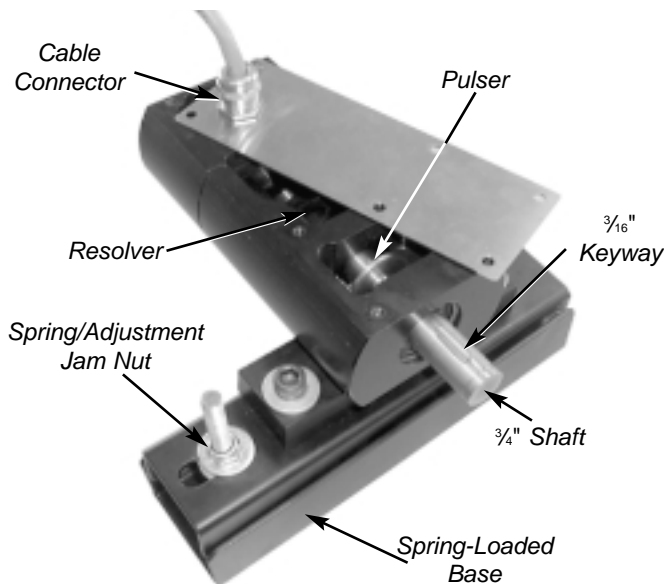

Photo 3.22
Part No. CMS115
Resolver/Pulser Assembly

CAUTION Do not run cable in conduit or in bundles with higher voltages that may cause electrical interference.

Photo 3.23
Resolver/Pulser Assembly
(Top of cover has been slid aside for photo)



The photoelectric pulser is monitored by the control logic to verify proper resolver position. Position changes can occur either mechanically or electrically. A mechanical failure can result if the resolver slips, and an electrical failure can result within the resolver cabling or circuitry. If failure occurs, the resolver position and the pulser cam signal will not match and the circuit logic will detect the fault. The pulser cam and resolver are connected internally to the connector provided; therefore, no wiring is necessary. The resolver/pulser is factory arranged for clockwise (CW) rotation (when facing the end of the shaft). A wiring change is required for counterclockwise (CCW) rotation. See the bottom of the next page or the enclosed wiring schematics for further details.

After installation of the resolver/pulser and wiring is complete with the machine at TDC (top dead center), perform the power-up procedure in Section 4 on page 44. This will automatically detect the pulser cam and set up the resolver for normal operation.

Photo 3.24
Resolver With Keyway
in Correct Position

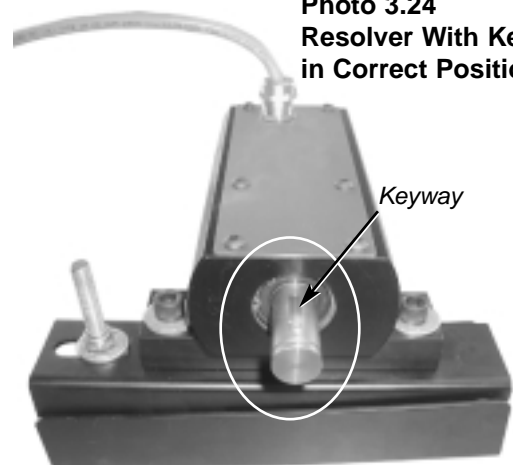

When installing a chain and sprocket or drive coupling to the $\frac{3}{4}$ " shaft, start with the machine at TDC (top dead center) and the keyway pointing up, perpendicular to the base (Photo 3.24). Connect the chain to sprockets or tighten the drive coupling. (See next page for sprocket and chain drive).

Note: If the resolver assembly is mounted on an angle or even upside down from what is illustrated, be sure the keyway on the shaft is always perpendicular to the base. The keyway must always be turned 180° away from the base when initially setting up the machine. The crankshaft of the machine must be at TDC.

(Continued on next page.)

SECTION 3—INSTALLATION OF COMPONENTS

SSC1500 Part-Revolution Solid-State Control

CONNECTING THE RESOLVER WIRES TO TERMINAL STRIP P5

When connecting the resolver wires to Terminal Strip P5, please follow the wiring schematics included with the control and see Photo 3.25. Strip the wires and crimp the supplied ferrules on each wire.* Terminal Strip P5 has a color-coded number label. Match each wire with the appropriate terminal in accordance with the wiring schematics and the color-coding. Make sure each wire is tight and making good contact with the metal part of the ferrule.

Forty feet of cable is supplied as standard and can be cut to length, if required. Do not splice the cable or interrupt the signals. If a longer cable is required, please contact the factory.







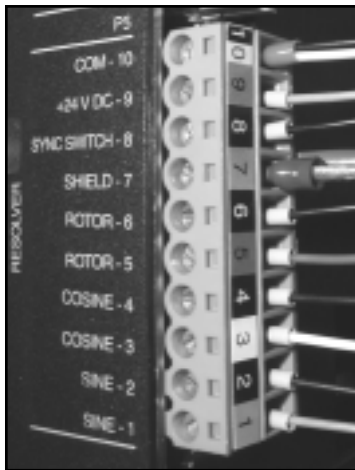

*A special crimping tool is required to properly crimp the ferrules on the wires. If you do not have one, it is available from:

Weidmuller Inc.
821 Southlake Boulevard
Richmond, Virginia 23236
Toll-Free: 1-800-849-9343
Phone: (804) 794-2877
Fax: (804) 794-0252
www.weidmuller.com

We use the Weidmuller Type PZ 3, Part No. 056730 crimping tool.



Photo 3.25—Terminal Strip P5 Wiring Connection on the SSC1500 Control Module



- 10—Black & Yellow (together in one ferrule)
- 9—Blue  paired
- 8—Black  paired
- 7—Five Bare Silver Shields (twisted together in large ferrule) & Green Panel Ground (no ferrule)
- 6—Black  paired
- 5—Red  paired
- 4—Black  paired
- 3—White  paired
- 2—Black  paired
- 1—Green  paired

Note: There is a brown and black wire pair with a silver shield in the resolver cable that is not used—cut and discard.

Note: The above wiring is for the resolver shaft to rotate clockwise. If the resolver needs to rotate counter-clockwise, the white/black and green/black pairs need to be swapped, such that:

- 4—Black  paired
- 3—Green  paired
- 2—Black  paired
- 1—White  paired

SECTION 3—INSTALLATION OF COMPONENTS

SSC1500 Part-Revolution Solid-State Control

Sprocket Assembly (If furnished)

Photo 3.26—Part No. CML000



Existing sprockets may be reused, or two sprockets with an identical number of teeth (usually 48) may be supplied. They are used to drive the resolver/pulser assembly. The standard set consists of one sprocket with the proper bore, keyway, and setscrews to mount directly on the shaft extension of the resolver. The other sprocket is flat with a small rough bore. This sprocket is normally mounted on the end of the machine crankshaft by drilling and tapping two suitable mounting holes in the sprockets and crankshaft and using spacer blocks, if necessary, to provide clearance for the chain. These sprockets use a standard ANSI No. 35 roller chain and connecting links.

SPECIAL SPROCKETS

Photo 3.27—Part No. CML100

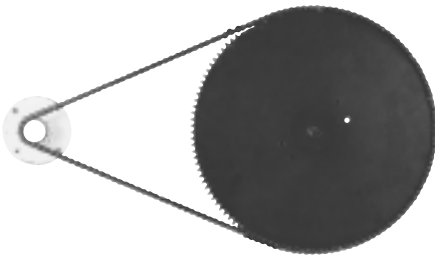

If your machine does not have access to the crankshaft to provide 1:1 ratio drive for the resolver/pulser assembly, special sprocket sets are available to match the gear drive ratio of the machine. The smaller of the two sprockets is attached to the drive of the machine (usually on the backshaft) and the larger sprocket is attached to the resolver/pulser assembly.

CAUTION Never hammer a sprocket or coupling on or off the resolver/pulser assembly shaft—this could damage the resolver/pulser assembly. It must be pressed on or off.

When installing the drive chain, it will be necessary to adjust the length of the chain in order to obtain proper action of the spring-loaded base of the resolver assembly. The normal position of the two hinged plates, on the resolver/pulser assembly, is approximately parallel with each other when the chain is installed. The spring is normally positioned between the two plates when the chain is pulling down (see Photo 3.28). When the chain is pulling up, the spring is above the top plate (see Photo 3.29).

Photo 3.28

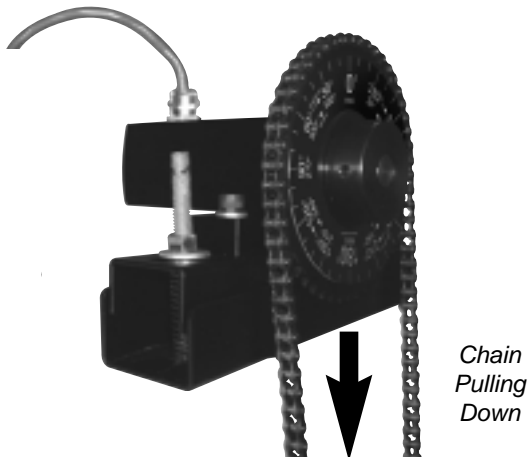
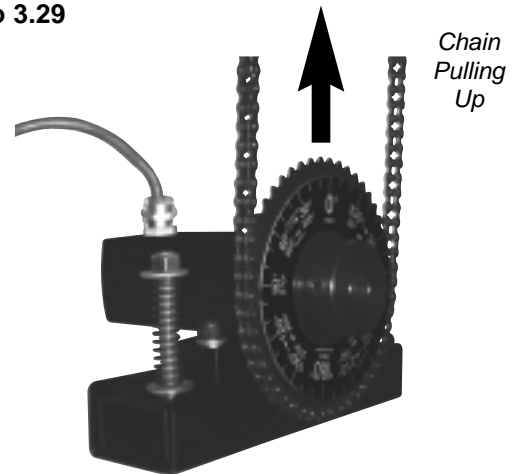

Photo 3.29



If a chain and sprocket drive already exists on a particular machine, it may be modified to drive the resolver. The resolver must always rotate exactly one revolution for each revolution of the machine crankshaft, therefore, the number of sprocket teeth must always match.

Note: If the press brake has a direct-coupling drive arrangement from the press brake or other timing device, the sprockets and spring-loaded base are not required. The spring base is furnished as a chain tightener, to help with misalignment and for shock isolation only. It is not used to detect chain breakage. The resolver has built-in motion detection that will sense if the sprocket stops rotating.

SECTION 3—INSTALLATION OF COMPONENTS

SSC1500 Part-Revolution Solid-State Control

Roller Chain (If furnished)

Photo 3.30
Part No. CMS515



Ten feet of ANSI No. 35 chain is usually furnished with each part-revolution control system. This chain is to be used with the supplied set of sprockets. A special master link for coupling the chain is furnished and this is used to connect the chain once the exact length has been determined.

Monitored Dual-Solenoid Air Valve (If furnished—See enclosed Manual KSL036)

Photo 3.31
Monitored Dual-Solenoid Air Valve
Part No. RCL554— $\frac{3}{4}$ "

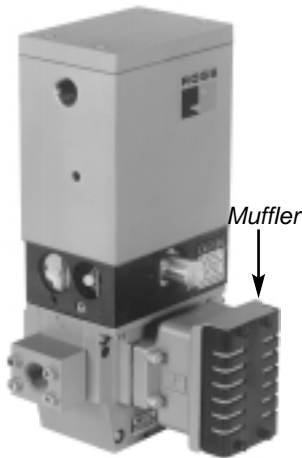

A minimum of 30 to 40 PSI must be maintained at the valve for proper operation. Use pipe size at least as large as the valve ports. An accumulator (air surge tank) is recommended for air-clutch press brakes. It would be installed in the incoming air line directly ahead of the valve to assure sufficient air volume to the clutch and brake.



The exhaust air muffer must be kept clean at all times. Never operate the machine unless the muffer is clean. The muffer must be removed and cleaned on a regular basis. If the machine has a split clutch and brake, two valves may be required. Both valves must be monitored dual valves with an electrical output signal to the control to indicate when one valve may have failed.

Filter-Regulator-Lubricator (FRL) Assembly (If furnished—See enclosed Manual KSL208)

The filter cleans air that goes to the dual-solenoid air valve. The regulator and gauge are used to adjust air pressure to the proper amount to engage the clutch and release the brake. The lubricator keeps the dual-solenoid air valve or the clutch/brake properly lubricated.

Choose an appropriate location on the machine for mounting this assembly. If possible, it should be accessible from floor level.

The length of the air line run to the surge tank is not critical; however, the port and pipe sizes should be maintained.



Photo 3.32
Part No. RCL045— $\frac{3}{4}$ "

The air filter must be kept clean at all times. Never operate the machine unless the air filter is clean. The lubricator must not be filled while under pressure.

SECTION 3—INSTALLATION OF COMPONENTS

SSC1500 Part-Revolution Solid-State Control

Standard and Special Air Cylinders

Required on mechanical-friction clutch press brakes only—not furnished for air clutch press brakes.

RCL SERIES AIR CYLINDERS (If furnished—See enclosed Manual KSL096)

Single-acting spring-return air cylinders are usually supplied with a swivel clevis mount as standard. Other special cylinders, such as clevis mount, flange mount (either end) or foot mount are also available. (See examples below.) They can be push-type (spring inside cylinder), or pull-type (spring on cylinder rod, as illustrated). The main consideration must be that the cylinder is a single-acting spring-return type (not double acting) to meet best safety practices. When mounting the cylinder, be sure it is secured in such a manner that it will not vibrate loose, bind or rub on some other part of the machine.



Photo 3.33
Spring-Return Air Cylinder

The air cylinder is usually mounted on the right side of the machine in the vertical position. On some occasions, with special air cylinders, they can be mounted horizontal on a special bracket (foot mount) or directly attached to the side frame. In any case, they should be mounted in the most logical position where they will operate the clutch and brake most efficiently. When applying an air cylinder to the machine, make sure that the cylinder rod, yoke or any moving parts will not bind after installation. Be sure the rod stroke is not too long because it could cause jack-knifing of the cylinder and clutch operating rod. (Shorter stroke cylinders are available.) Too much air pressure may damage clutch/brake operating linkage. Please consider these points when installing any air cylinder.

The purpose of the spring on the cylinder is to help the return action of the linkage to disengage the clutch and apply the brake. All existing spring action must remain in the linkage and clutch/brake even if they have to be relocated to accommodate the air cylinder.

SPECIAL CYLINDERS (If furnished—See enclosed Manual KSL096)

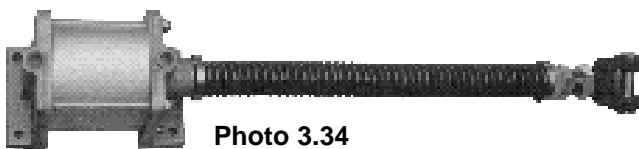

Photo 3.34
Special Side-Mount Air Cylinder

The following are examples of tie-rod constructed air cylinders which may be furnished in place of the standard RCL series cylinders above. These cylinders are furnished when the standard cylinder is not large enough or if a more durable cylinder is needed to engage and disengage the mechanical-friction clutch and brake of press brakes or when the standard clevis mount offered will not fit the machine.

Note: These are offered in tie-rod construction, both pull-type and push-type, single action with spring return.

On push-type cylinders, the spring is inside the cylinder. All cylinders are furnished with a yoke and pin on the operating rod, which is used for attaching the cylinder to the machine operating linkage.

An adjustable air flow control muffler can be added to the breather port on the special tie-rod air cylinders. This adjustment allows the cylinder to pull at a slower and smoother rate. If this flow control muffler restricts air too much, it will cause the clutch and brake to react slower, thus increasing the stopping time. This must be a consideration when applying either two-hand control or a presence-sensing device, since the safety distance they are placed at is based on the machine's stopping time.

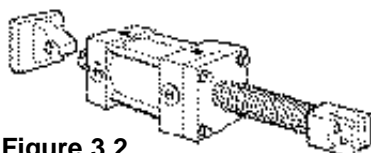

Figure 3.2
Clevis-Mount Pull Type

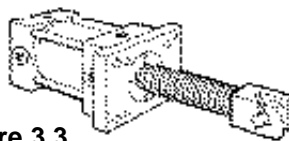

Figure 3.3
Front-Flange Mount Pull Type



Figure 3.4
Side-Foot Mount Push Type

Please consult the factory for any other special cylinder configuration (such as longer or shorter stroke) or additional force needed on the return spring.

(Continued on next page.)

SECTION 3—INSTALLATION OF COMPONENTS

SSC1500 Part-Revolution Solid-State Control

Standard and Special Air Cylinders (continued)

Figure 3.5
Standard Pull
Cylinder With Clevis
Mount on Right
Side of Press Brake

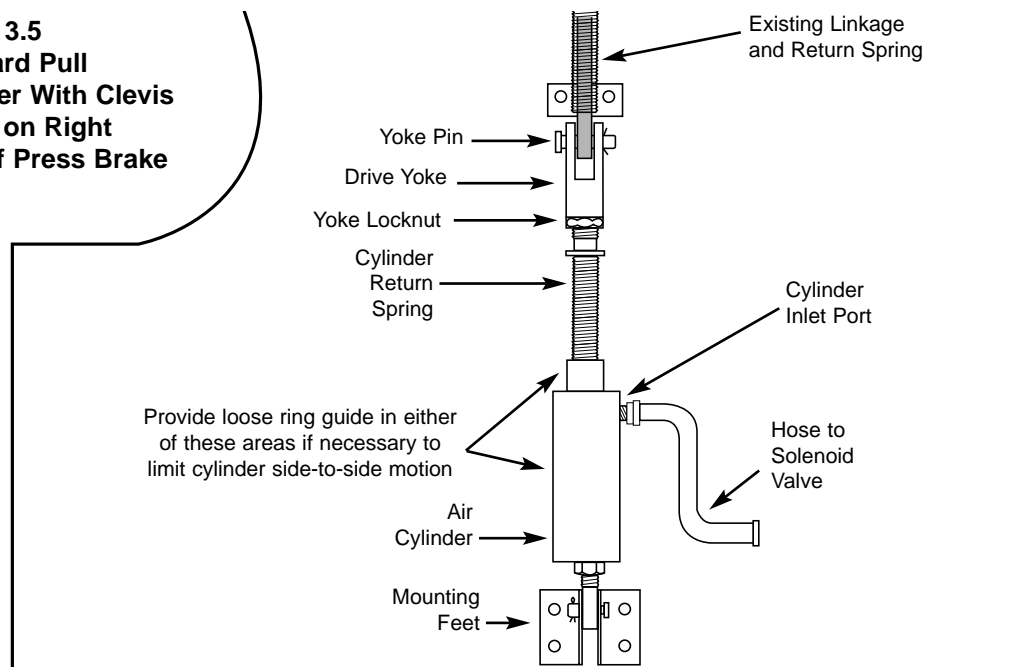

Air Pressure Switch (If furnished—See enclosed Manual KSL165)



Photo 3.35
Part No. CTD062

The clutch/brake air supply must be monitored by an air pressure switch on all part-revolution press brakes. If an air counterbalance is used, it must also be monitored by a separate air pressure switch. Please check the machine owner's manual for the minimum suggested air pressure for these switches.

Mount this switch at any convenient location on the machine. Electrical and pneumatic connections to the switch are required; therefore, its location is determined by the installer. Flexible hose is often used for air connections. Since only air pressure is being monitored, tubing size can be small and length is not critical. The switch is set to open the electrical circuit any time pressure falls below the preset level. It is normally set in the 30 to 40 PSI range to prevent unnecessary opening due to a surge in line pressure during the clutch engaging period. The minimum setting for the air counterbalance pressure may be in the 20 to 30 PSI range (see machine manufacturer's recommendations).

Check Valve for Counterbalance System (If furnished—See enclosed Manual KSL038)

Photo 3.36
Part No. RCD061— $\frac{1}{2}$ "
Part No. RCD062— $\frac{3}{4}$ "
Part No. RCD063—1"
Part No. RCD064— $1\frac{1}{2}$ "
Part No. RCD065—2"



If the machine is equipped with an air counterbalance system, a check valve is required by OSHA to prevent a sudden loss of air pressure to the system. This valve is available in various sizes. The size is determined by the pipe size of the incoming air supply to the air tank, which supplies the air to the counterbalance system. The valve should be installed in the air line just before the tank. When complete energy isolation is required, for maintenance on the machine or counterbalance system, be sure that air is released from the counterbalance, cylinders, tank, etc.

CAUTION Do not install this valve between the cylinders and tank.

SECTION 3—INSTALLATION OF COMPONENTS

SSC1500 Part-Revolution Solid-State Control

Palm Button Assembly (If furnished—See enclosed Manual KSL073)

1. A palm button assembly will consist of three buttons (two black run/inch buttons with ring guards and one red emergency-stop button). Three mounting boxes are supplied (two double-hub and one single-hub). Optionally available are the Touchdown!™, chrome, or articulated light-push palm buttons. These may be furnished in place of the standard black run/inch palm buttons. These palm buttons can be assembled in the order shown in Figure 3.6 and mounted according to the requirement of the application. Nipples, conduit, and wire for connecting the mounting boxes are not furnished.

 **Install the palm run buttons in such a way that they require the use of both hands to cycle the press brake.**

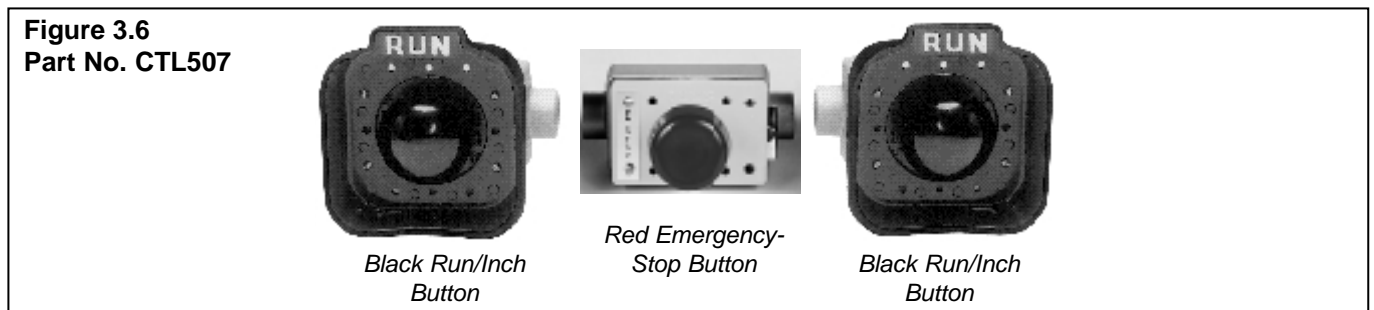

2. The two run palm buttons, on part-revolution-clutch machines, can be used to initiate a machine cycle and as a method of safeguarding the point of operation. In both instances, OSHA and ANSI have established certain requirements for these buttons. For your convenience we have reproduced the pertinent sections of ANSI B11.3 as well as the safety distance formula for two-hand control. These sections cover two-hand control as an initiating means and two-hand control as a point-of-operation safeguard for part-revolution-clutch press brakes.

Please read and make sure you understand the following sections before proceeding with the mounting of the two run buttons.

ANSI B11.3:

6.11.3.2 Two-hand control

When a two-hand operator control is provided, each hand control shall be protected against unintended actuation and arranged by design, construction, or separation, or a combination thereof, so that the concurrent activation from both hands is required to actuate the press brake.

8.6.5 Two-hand control safeguarding device

8.6.5.1 Design and construction

8.6.5.1.1 The two-hand control device shall have individual hand controls arranged by design, construction, or separation to require the use of both hand controls for actuation.

8.6.5.1.2 The two-hand control device shall meet the requirements of ANSI/NFPA 79 and shall be a type 3 control.

8.6.5.1.3 If more than one operator is to be safeguarded by the use of two-hand controls, each operator shall have individual hand controls. The selection of the two-hand control shall be capable of being supervised by the user.

The control system shall be designed and constructed so as to prevent cycling of the machine if all the operator's stations are deselected.

(Continued on next page.)

SECTION 3—INSTALLATION OF COMPONENTS

SSC1500 Part-Revolution Solid-State Control

Palm Button Assembly (continued)

ANSI B11.3 (continued):

8.6.5.1.4 A single failure of a component, a subassembly or a module of the two-hand control device that affects the performance of the safety-related functions shall not prevent a normal stop command from being initiated or shall cause an immediate stop command. In the event of a failure, re-initiation of the press brake shall be prevented until the failure is corrected or the system or device is manually reset.

In the presence of a failure, repetitive manual reset of the system or device shall not be used for production operation.

8.6.5.2 Installation and operation

8.6.5.2.1 A two-hand operating lever, trip, or control device shall be installed, operated, and maintained in accordance with this standard.

8.6.5.2.2 The device shall be located at a distance from the nearest hazard such that the operator cannot reach the hazard before cessation of hazardous motion. The two-hand operating lever, trip, or control device shall require concurrent actuation of both of the operating levers or hand controls to initiate a machine cycle.

8.6.5.2.3 The two-hand control device shall require the concurrent actuation of the operator's hand controls during the hazardous portion of the machine cycle such that the operator cannot reach the hazard before the hazardous motion has ceased.

8.6.5.2.4 The interface of the device and the machine control system shall be such that a single failure of a component, a subassembly or a module of the interface that affects the performance of the safety-related functions shall not prevent a normal stop command from being initiated or shall cause an immediate stop command. In the event of a failure, re-initiation of the press brake shall be prevented until the failure is corrected or the system or device is manually reset.

In the presence of a failure, repetitive manual reset of the system or device shall not be used for production operation.

8.6.6 Single control safeguarding device

Actuating controls used for single control safeguarding devices shall be located at a safe distance.

3. According to ANSI B11.3-2002, the total stopping time of the press brake (for two-hand control) should include the total response time of the control system and the time it takes the press brake to cease ram motion. The following formula should be used when calculating the safety distance:

$D_S = K (T_S + T_C + T_R + T_{spm})$; where:

K = the hand speed constant = 63 inches/second.

T_S = stopping time of the press measured from the final deenergized control element (usually the air valve).

T_C = the reaction time of the control system.

Note: $T_S + T_C$ can be measured by a built-in stop-time measurement device.

T_R = the reaction time of the two-hand control and its interface.

Note: $T_S + T_C + T_R$ can be measured by a portable stop-time measurement device.

T_{spm} = the additional time allowed by the stopping performance monitor (brake monitor) before it detects stop-time deterioration.

When the press stroke stop command or stopping performance monitor (brake monitor) timer or angle setting is changed, because the machine is taking longer to stop, the safety distance should be recalculated. The safeguarding device should also be placed at a greater safety distance if the stopping time or distance has increased.

Note: When obtaining the stopping time using the ANSI formula, a stopping position of crankshaft rotation is not provided. To calculate the safety distance, the stop signal should be given on the downstroke at a point that would provide the longest stopping time.

(Continued on next page.)

Palm Button Assembly (continued)



When applying the two run palm buttons to meet the requirements for a point-of-operation safeguarding device, make certain these buttons are located on the machine so they meet the minimum safety distance required by the ANSI formula.

Simply stated, safety distance is the mounting location of the palm buttons at a distance where the operator cannot reach into the point-of-operation hazard before the slide has stopped or completed its downward travel.

To obtain the stopping time, either the built-in system (provided with the control system) or a portable stop-time measurement unit can be used.

WHEN USING FOOT SINGLE STROKE AND FOOT/FOOT SEQUENCE STOP MODES OF OPERATION:

A method of safeguarding the point of operation must be provided before using any of the above modes of operation.

The machine will not operate or must not be operated until you either:

1. Electrically interlock or
2. Mechanically safeguard the machine's point of operation with a guard or device.

Install either the electrically interlocked method of safeguarding or the mechanical guard or device.

1. When an electrically interlocked method of safeguarding the point of operation is chosen, connect the interlock to the **safeguard interlock** terminals (P8-17 and P8-18) in the control box, and as shown on the control wiring schematic (wire numbers 86 and 87). If a light curtain is used as the point-of-operation safeguard, it does not need to be interlocked in to P8-17 and P8-18. Refer to the control wiring schematic for proper terminal connection.
2. When a mechanical guard or device (nonelectrically interlocked) is chosen, the safeguard interlock terminals (P8-17 and P8-18) are not used. In order for the machine to operate with the use of a mechanical guard or device, the safeguard interlock terminals must be connected.

Note: When the mechanical guard or device is removed for other modes of operation, the safeguard interlock terminals must be disconnected.

RED EMERGENCY-STOP BUTTON (Required)

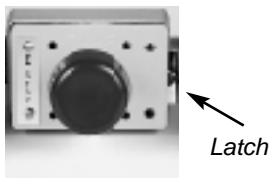

Photo 3.37
Part No. CTC736

The red emergency-stop button is used to stop the machine anywhere in its cycle. When the operator depresses the button, it should stop the hazardous motion of the machine immediately. This palm button assembly requires either a double-hub mounting box **Part No. CTK003**, or a single-hub mounting box **Part No. CTK004**. The button can be located between the two run palm buttons as part of the operator's control station (refer to page 31). A latch on the side trips when the button is pushed. To reset the button, push the latch in.

Note: More than one emergency-stop button may be furnished for additional control stations or for convenience.

SECTION 3—INSTALLATION OF COMPONENTS

SSC1500 Part-Revolution Solid-State Control

Palm Button Assembly (continued)

Control bars that include the palm buttons previously shown are also available. A control bar can include the emergency-stop palm button, and the multiple-operator supervisory selector switch and indicator light. See the control bar wiring schematics for proper wiring.

Photo 3.38
Example of a
Control Bar



A palm button assembly or control bar can be mounted on a floor stand. If two-hand control is used as a method of safeguarding the point of operation, the floor stand must be fixed into position at the required safety distance.

Photo 3.39
Part No. KCL000

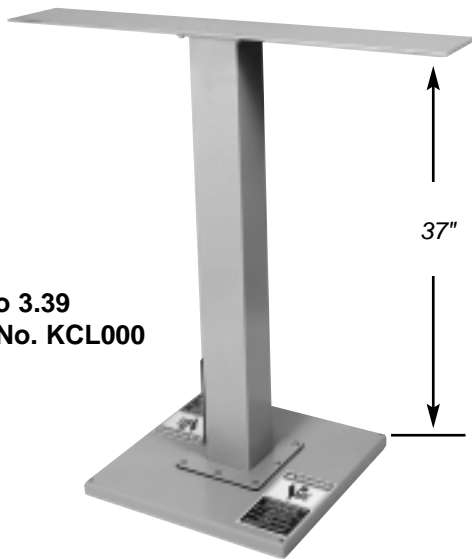

Photo 3.40
Part No. KCL017



SECTION 3—INSTALLATION OF COMPONENTS

SSC1500 Part-Revolution Solid-State Control

Palm Button Assembly (continued)

Two-hand control is furnished with the SSC1500 control and can be used as a point-of-operation device. If it is going to be used as a point-of-operation device, the following function tests should be run before operating the press. These tests should be done at every operator, die, or shift change, and every time maintenance is performed.

1. Verify that the two-hand control complies with the following before stroking the press brake.
 - a. Are the palm buttons protected against accidental operation (with ring guards or fabricated shields)?
 - b. Are the palm buttons separated by enough distance or configured to require the use of both hands to actuate the press brake?
 - c. Are the palm buttons at the proper safety distance based on the stopping time of the machine on the downstroke? (See page 32 for details.)
 - d. Are the palm buttons fixed in position?
2. With the main motor drive on, the flywheel rotating, the actuating means selector switch set to **HAND**, and the mode selector switch set to **SINGLE**, perform the following tests.
 - a. Depress both palm buttons concurrently within the programmed anti-tie-down setting (100-7000 ms) and the machine will begin a stroke.
 - b. Hold the palm buttons down for the entire stroke. Release one palm button and try to start another stroke by reactuating the palm button that was just released. The machine should not begin another stroke. Repeat this step with the other palm button. The machine should not begin another stroke. This verifies the control has antirepeat.
 - c. Depress both palm buttons and release only one palm button on the downstroke. The machine's slide should stop. Reactuate the palm button that was released. The machine should not finish the stroke. Both palm buttons must be released and reactivated in order for the machine to finish the stroke. Repeat this test while releasing the other palm button. The machine should not finish the stroke. Both palm buttons must be released and reactivated in order for the machine to finish the stroke. This verifies the control has nonresumption of interrupted stroke.



If any of these function tests fail, corrective action must be taken before running production.

Foot Switch (If furnished—See enclosed Manual KSL001)



If you elect to use a foot switch, all personnel must be warned that it is impossible for a foot switch to provide any form of point-of-operation safeguarding. It is the responsibility of the employer (user) to always provide an appropriate guard and/or device to prevent bodily injury whenever a foot switch is used to initiate a machine cycle. (See ANSI B11.3.)

The following steps should be taken when using a foot switch:

A method of safeguarding (light curtain, guard, gate, pullback, or restraint) the point of operation must be provided before installing or using a foot switch.

The machine will not operate or must not be operated until you either:

1. Electrically interlock or
2. Mechanically safeguard the machine's point of operation with a guard or device.

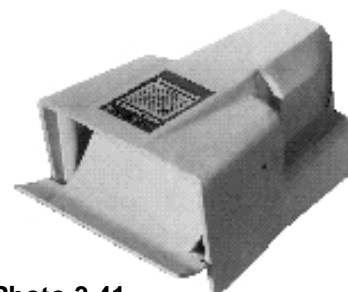

Photo 3.41
Part No. CTD011

(Continued on next page.)

SECTION 3—INSTALLATION OF COMPONENTS

SSC1500 Part-Revolution Solid-State Control

Foot Switch (continued)

Install either the electrically interlocked method of safeguarding or the mechanical guard or device.

1. When an electrically interlocked method of safeguarding the point of operation is chosen, connect the interlock to the safeguard interlock terminals (P8-17 and P8-18) in the control box and as shown on the control wiring schematic (wire numbers 86 and 87). If a light curtain is used as the point-of-operation safeguard, it does not need to be interlocked in to P8-17 and P8-18. Refer to the control wiring schematic for proper terminal connection.
2. When a mechanical guard or device (nonelectrically interlocked) is chosen, the safeguard interlock terminals (P8-17 and P8-18) are not used. In order for the machine to operate with the use of a mechanical guard or device, the **safeguard interlock** terminals must be connected.

Note: When the mechanical guard or device is removed for other modes of operation, the safeguard interlock terminals must be disconnected.



Never use a foot switch to operate this machine unless a point-of-operation guard or device is provided and properly maintained.



The mechanical guard or device must be properly installed, used and maintained. It must always prevent all personnel from bodily injury.



If the mechanical guard or device is not used, is removed or is defeated, an electrically interlocked method of safeguarding must be used and connected to the safeguard interlock terminals P8-17 and P8-18.

When installing the optional foot switch, be sure the wiring schematics are referenced for proper connections. Be sure to maintain the foot switch in first-class condition. It must always be wired properly and the protection on the top, sides, and front must always remain in place.

Supervisory Control Station (If furnished)

When two or more palm button or foot switch operating stations are required on one machine, one supervisory control station is required at each operator station. This remote control station consists of one station on indicator light and an off/on keyed selector switch in an enclosure. The on position allows the operator to use that station and the off position deactivates only that station. If all the supervisory control stations are in the on position, the palm buttons or foot switches must be depressed within the timing period set in the anti-tie-down program (page 67) in order to initiate a machine stroke.



Photo 3.42
Supervisory Station
Part No. LLD1501
Part No. LLD283 (Required when USC-000 multiple-operator junction box is used; see below)

Note: If the USC000 multiple-operator junction box is used, the anti-tie-down setting in the SSC1500 control becomes irrelevant, since the junction box has its own timers.

Multiple Operator Junction Box (If furnished—See enclosed Manual KSL266)

When multiple operator stations are required, this junction box is furnished separately for wiring up to four (4) operator stations. This junction box interfaces palm button assemblies/control bars and foot switches, and will not allow the press brake to run if palm buttons or a foot switch is actuated without its supervisory control station on. Refer to the electrical schematic furnished with your order for proper wiring of each station.



Photo 3.43
Multiple-Operator Junction Box
Part No. USC000

SECTION 3—INSTALLATION OF COMPONENTS

SSC1500 Part-Revolution Solid-State Control

Other Components That Could Be Interfaced to the Control

Interlocked Guard	Feed System	Die Light
Light Curtain*	Bumper Pin	Conveyor
RF Device*	Flywheel Brake*	Motion Detector*
Gate*	Tachometer*	Bearing Heat Sensors*
Air Blowoff	Digital Shut-Height Indicator*	Overload Protection*
Additional Counters	Brake Monitor*	Robot*
Indexing Table*	Hour Meter	Additional Programmable Limit Switch*
Sliding Bolster*	Material Feeding Equipment*	Safety Block Electrical Interlock System
Additional Die Protection*	Material Straightener	Lubrication System*
Bar/Run Station	Reel Cradle for Coil	

*The electrical or electronic schematics are required if Rockford Systems is to interface this equipment to the control.

Other Components That May Be Required

AIR LOCKOUT VALVE (If furnished—See enclosed Manual KSL098)

OSHA 29 CFR 1910.147 requires that all employers develop a complete hazardous energy control program. This standard covers the servicing and maintenance of machines and equipment where the unexpected energization or start-up of the machines or equipment, or release of stored energy could cause injury to employees. The following should be included when establishing a program:

1. Use procedures for affixing lockout or tagout devices to energy isolating devices. Also, disable machines or equipment to prevent unexpected energization, start-up, or release of stored energy in order to prevent injury to employees.
2. After establishing a hazardous energy control program, periodic inspection of the energy control procedure must be done at least annually.
3. Training of employees to ensure the purpose and function of the energy control program is understood.
4. When establishing procedures for shutdown:
 - Identify all energy sources.
 - Know the hazards of the energy to be controlled.
 - Determine the methods or means to control energy.
5. Hazardous energy sources associated with machinery are:
 - Electrical
 - Pneumatic
 - Hydraulic
 - Fluids and Gases
 - Mechanical

INSTALLATION OF LOCKOUT VALVE

When ready to install a lockout valve (if furnished), remove plastic dust covers from the valve port connections. Avoid getting particles such as chips, sealing compounds, or scale in the piping. This can cause valve failure and damage. See Figure 3.7 on page 38 for a diagram of where the lockout valve could be located and for additional instructions on installing lockout valves.

(Continued on next page.)

SECTION 3—INSTALLATION OF COMPONENTS

SSC1500 Part-Revolution Solid-State Control

Figure 3.7

Illustration of where an air lockout valve could be located in the air line on part-revolution press brake

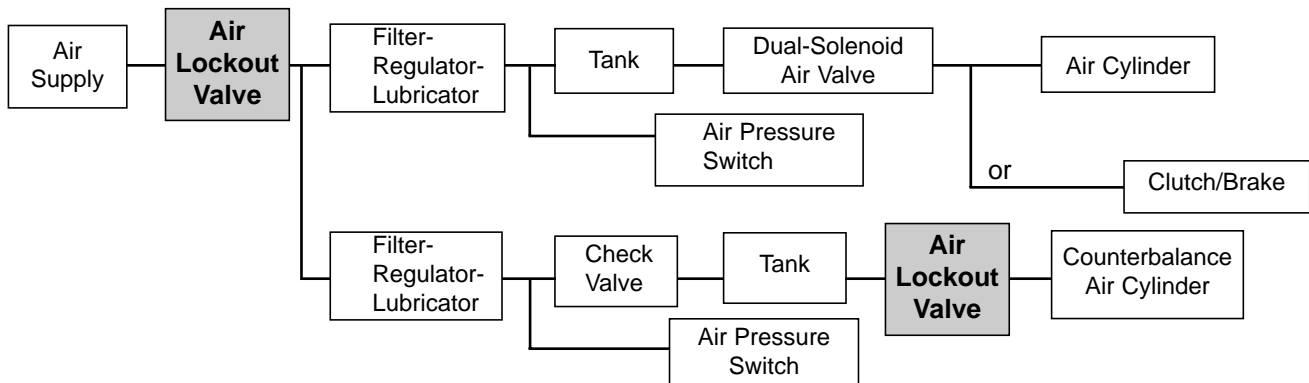

TYPES OF LOCKOUT VALVES THAT CAN BE FURNISHED

Manual Valve

This valve is installed in the air line going to the machine. To exhaust air in the line, the handle is pushed in. This valve is available in port sizes $\frac{3}{4}$ " and 1".



Photo 3.44



Photo 3.45

Manual Pilot Valve

This valve is used for air systems that are larger than those that can be used with the manual valve. Port sizes are $1\frac{1}{2}$ " and $2\frac{1}{2}$ ".

Slide-Operated Valve

This three-way valve is opened with the manual movement of a slide that opens and closes the valve. This valve shuts off air at the press and then bleeds off downstream air. This valve is available in port sizes $\frac{1}{2}$ " and $\frac{3}{4}$ ".



Photo 3.46

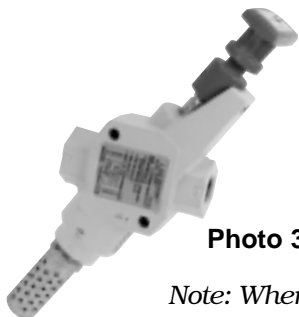

Photo 3.47

EEZ-On Valve

This valve shuts off air supply to the machine and bleeds downstream air when the valve is closed. When the valve is open, it gradually allows air into the air system to prevent damage to air components. It can be locked only in the off position. This valve is available in port sizes $\frac{1}{2}$ " and $\frac{3}{4}$ ".

Note: When any of these valves are manually closed, the downstream air is automatically drained, provided there is not a check valve or obstruction in the air line.

(Continued on next page.)

SECTION 3—INSTALLATION OF COMPONENTS

SSC1500 Part-Revolution Solid-State Control

TYPES OF LOCKOUT VALVES THAT CAN BE FURNISHED (continued)

Figure 3.8

VALVE TYPE	PART NUMBER	IN/OUT PORT	EXHAUST PORT	VALVE BODY WITHOUT MUFFLER	MUFFLER
Manual	RCD076	3/4"	1"	RCD086	RCS044
	RCD077	1"	1"	RCD087	RCS044
Manual Pilot	RCD078	1 1/2"	1 1/2"	RCD088	RCS006
	RCD079	2 1/2"	2 1/2"	RCD089	RCS038
Slide-Operated	RCD113	1/2"	N/A	N/A	N/A
	RCD114	3/4"	N/A	N/A	N/A
EEZ-On	RCD121	1/2"	3/4"	RCD118	RCS043
	RCD122	3/4"	3/4"	RCD119	RCS043

MAIN POWER DISCONNECT SWITCH

A main power disconnect switch may have been supplied in this control package shipment as a separate component or included in a custom or special control box. This switch is designed to disconnect the primary voltage to the press and lock it out. Please refer to the enclosed wiring schematics for proper wiring of this switch.

ANSI B11.3 and NFPA 79 require that:

1. A main power disconnect switch capable of being locked in the off position only shall be provided with every power press brake control system.
2. If the machine already has a main power disconnect switch, it must be checked for the "locking off" feature. Some switches use construction which can be easily altered mechanically to comply with this requirement. If this is not possible, or an electrical disconnect switch is not provided, then you must obtain and install a proper disconnect switch. (For a proper disconnect switch, please contact Rockford Systems.)

MOTOR STARTER

A reversing or nonreversing motor starter may have been supplied with this control package as a separate component or included in a custom or special control box. The main purpose of this starter is to start and stop the main motor and to drop out the main motor when a power failure occurs. Please refer to the enclosed wiring schematics for proper wiring of this starter. If an existing starter is used, a 120-V AC coil and N.O. auxiliary (main motor forward) contact are required.

ANSI B11.3 and NFPA 79 require that:

1. When provided, the motor start button shall be protected against unintentional actuation.
2. All press brakes, except air operated press brakes, shall incorporate a type of drive motor starter that will disconnect the drive motor from the power source in the event of control voltage or power source failure, and require actuation of the motor start button to restart the motor when voltage conditions are restored to normal.

These requirements are normally met by using a magnetic motor starter. This starter should operate with a 120-V AC coil which is powered from the secondary of the control transformer on the control panel. Refer to the electrical schematics supplied to obtain details of how to wire the starter and associated motor start/stop push buttons.

For proper tie-in of the furnished clutch/brake controls, the starter requires an auxiliary normally open contact. (For a proper starter, please contact Rockford Systems.)

CUSTOM OR SPECIAL CONTROL BOX

In place of the standard control box previously described, you may have ordered and received a custom or special control box. This box usually includes a magnetic motor starter and disconnect switch complying to the previously described requirements. Be sure to wire in primary voltage and components to terminals as indicated on the enclosed wiring schematics. 120-V electrical power to clutch/brake controls, operator controls, solenoids, etc., must be obtained from a transformer with isolated secondary.

SECTION 3—INSTALLATION OF COMPONENTS

SSC1500 Part-Revolution Solid-State Control

FLYWHEEL AND GEAR COVERS

According to OSHA 29 CFR 1910.219 and ANSI B15.1 for mechanical power-transmission apparatus, all rotating components including flywheels, gears, sprockets and chains, sheaves and belts, shaft ends, etc., must be covered if at or below a seven-foot level from the floor or platform. *Note: ANSI states it should be a nine-foot level.* Adequate cover material and brackets must be fabricated to retain these components in event of shaft or wheel mounting failure.

COLLATERAL EQUIPMENT

All collateral press room and plant equipment such as spring or air slide counterbalances, die cushions, feeding equipment, and robots must be safeguarded if they create hazards to personnel.

POINT-OF-OPERATION SAFEGUARDS

OSHA 29 CFR 1910.212 (a)(ii) requires that:

“The point of operation of machines whose operation exposes an employee to injury, shall be guarded. The guarding device shall be in conformity with any appropriate standards therefor, or, in the absence of applicable specific standards, shall be so designed and constructed as to prevent the operator from having any part of his body in the danger zone during the operating cycle.”

Refer to Section 9 for examples of point-of-operation safeguards for power press brakes.

Other Installation Considerations

PIPING

1. An air lockout valve must be installed in the air line usually just before the filter-regulator-lubricator assembly to meet OSHA 29 CFR 1910.147 Lockout/tagout requirements. However, a separate lockout valve could be furnished for each air system on the machine such as counterbalance, clutch/brake, air cylinder, and blow-off.
2. From the lockout valve, connect at the **In** threaded opening of the filter-regulator. Try to maintain an appropriate pipe size throughout for proper air flow. Connect the piping to the ports using teflon tape on the male threads only. Do not allow tape to enter the interior of the filter-regulator-lubricator, valve, or air cylinder. Before applying air pressure, make sure the filter and regulator bowls are at least hand tight.
3. Most approved pipe or hose can be used on the press. Make sure the size is consistent throughout the system in order to avoid restriction. Keep air runs as short as possible.
4. See enclosed filter-regulator-lubricator (FRL) assembly Manual No. KSL208 for additional details.

CAUTION All air components require clean air. Blow all lines clean of water, dirt, scale, etc., before making final connection. Drain water from filter bowl regularly. Should this bowl refill in a short period of time, it may indicate the need for a larger filter in the main air supply line or an air line dryer system. The air filter must be kept clean at all times. Never operate the machine unless the air filter is clean and water is drained.

WIRING

National Electrical Code and NFPA 79 practices are usually followed for wiring the control system, which includes color-coding and the use of numbered wire markers on **both ends of every wire**. Color-coding is black for line voltage (208, 230, 460, or 575 V) and control at line voltage, red for 120-V AC control circuits, blue for 24-V DC control circuits, white for current-carrying ground (commonly referred to as the neutral) and green for any equipment grounding conductor. All terminal blocks in the control cabinet are color-coded for easy identification.

- a. Install and wire the main disconnect switch (unless one already exists or is furnished in a custom control) using black wire. Follow wiring instructions shown on the electrical schematics. Make certain this switch is capable of being locked in the off position only.

(Continued on next page.)

SECTION 3—INSTALLATION OF COMPONENTS

SSC1500 Part-Revolution Solid-State Control

WIRING (continued)

- b. Install and wire the motor starter (unless one already exists or is installed in a custom control box) using black wire for the power, red and white wires for the coil and interlock circuit, and blue for the motor forward connection to the control module.
If an existing starter does not have a 120-V AC coil, a new 120-V AC coil must be obtained, installed and wired in accordance with the schematics provided before proceeding. An additional auxiliary normally open contact may also be required in the starter. (Do not run a separate 120-V line to the machine for operating the clutch/brake controls.)
- c. All necessary inputs and outputs to the control module are prewired from the printed circuit board terminals to the color-coded terminal strips for installation. No wiring on the printed circuit board terminals is necessary.
- d. Run two black power lines (any two lines) from the load side of the disconnect switch (or from the line side of the motor starter) to the control enclosure. Connect the two black wires to the proper terminals on the control transformer (see electrical schematic or transformer nameplate for proper connections for different primary voltages). *Note: If a custom control box with a disconnect has been provided, this step is not necessary.*
- e. Run a green ground wire from the incoming system ground to the control panel.
- f. Wire the motor starter and start/stop controls according to the connection schematics. *Note: If a custom control box with a starter has been provided, this step is not necessary.*
- g. To wire the dual-solenoid air valve, see the enclosed Installation Manual No. KSL036 and the wiring schematics. The exhaust air muffler must be kept clean at all times. Never operate the machine unless the muffler is clean.

KEYPAD/DISPLAY ASSEMBLY

Refer to page 22 for the wiring of the keypad/display assembly.

RESOLVER/PULSER ASSEMBLY

Refer to pages 25-26 for the wiring of the resolver/pulser assembly.

AIR PRESSURE SWITCH(ES) (See page 30)

Run ½" nominal conduit from pressure switch(es) to the control box. Pull the appropriate number of wires through conduit. Number the wires according to the diagram and connect to terminals at both ends. These pressure switches always use the normally open contact which is held closed by normal air pressure. Loss of air pressure will open this contact and render the control inoperative. The normally closed contact provides a signal to one of the user-programmable diagnostic inputs.

PALM BUTTON ASSEMBLY (See pages 31-35)

These are normally wired as an assembly with the blue wires routed from the control box to the nearest palm button and then the others, as required. Wires between the two run/inch buttons are not connected back to the control box. If Touchdown!TM (proximity) palm buttons are furnished, please refer to the enclosed Installation Manual No. KSL073 and the connection print provided.

If the palm button assembly is not bolted directly to the machine frame, then a separate green ground wire should be run from the control box to all palm buttons. Attach one end of the wire to each mounting box by a lug under one of the mounting bolts and the other end of the wire to the GND terminal in the control box to assure proper grounding.

(Continued on next page.)

SECTION 3—INSTALLATION OF COMPONENTS

SSC1500 Part-Revolution Solid-State Control

PALM BUTTON ASSEMBLY (continued)

These operator controls should be mounted in a convenient location, keeping ergonomics in mind. To comply with the ANSI standard for two-hand control, the run/inch buttons must be located according to the minimum safety distance requirements of each individual machine as defined by ANSI B11.3 (see page 31 of this manual). A stop-time measurement is necessary for checking stopping time before installation begins to determine the safety distance of the two-hand control palm buttons furnished with the control. After installation, the stopping time can be obtained from the built-in stop-time measurement system or a portable stop-time measurement unit.

CONTROL BAR (See page 34)

Mount the control bar at the required safety distance either on the machine or on a floor stand. See the wiring schematics for proper wiring of the control bar.

FOOT SWITCH (See pages 35-36)

Run ½" nominal flexible conduit or cord from the foot switch to the control box. Connect the contacts according to the control drawing schematic. In general, connect one wire from one side of the normally open and normally closed contacts to a COM terminal, and a wire from the other side of each contact to the appropriate control module input terminal. If multiple foot switches are used, the COM connection may be split up. Refer to the multiple operator drawing for wiring details. Be sure to connect the ground in the foot switch to the GND terminal in the control box with a green wire.

SUPERVISORY CONTROL STATION (See page 36)

Mount the station in a convenient location where it is easily accessible, or as part of a palm button assembly. See the wiring schematic for proper wiring of the supervisory control station.

MULTIPLE-OPERATOR JUNCTION BOX (See page 36)

Run ¾" nominal conduit from the junction box to the control box. Pull the cable through the conduit and connect it to the appropriate terminals according to the junction box drawing. Connect each supervisory control station to the multiple-operator junction box with the cable. *Note: The junction box should be located for easy access to the fault reset button in case a fault should occur.*

* * * MACHINE GROUND * * *



The machine frame must always be firmly connected to ground in order to avoid problems with the control and to ensure the control potential will never exceed 120 V above ground. Run a green grounding wire from the control box to some convenient location directly on the machine frame. Connect one end solidly to the frame using a mounting bolt or other convenient means of attachment. Scrape any paint, rust, etc., from the area to ensure an adequate ground connection. Connect the other end to the GND terminal in the control box.

Note: All exposed metal components, which may be touched by personnel during normal operation or adjustment, must be firmly grounded to the machine frame. The disconnect switch and motor starter should also be grounded if they are mounted separately.

Setup of Control System

The flowchart in Figure 4.1 outlines the order and method of setting up and programming the SSC1500 control system on a part-revolution-clutch press brake after installation. Refer to the display on the control box or on the remote operator station.

Figure 4.1
Programming Flowchart

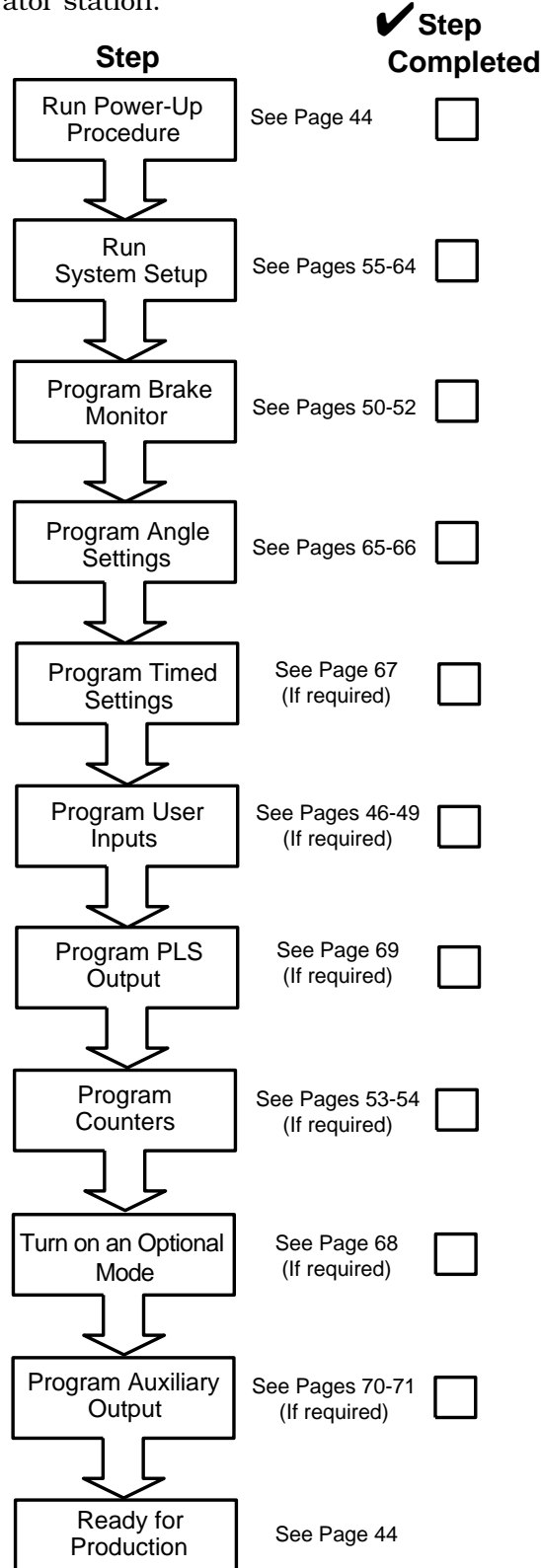

SECTION 4—PROGRAMMING

SSC1500 Part-Revolution Solid-State Control

Power-Up Procedure

After completing the installation of the control box and control components, the SSC1500 press brake control system must be initially programmed according to the flowchart in Figure 4.1 on page 43 to get the machine up and running. Before programming, the control must first be powered up.

Turn the main power disconnect switch for the control to the **ON** position and start the main motor. After detecting the network for a few seconds, the current main CPU software version is displayed on the WAKE-UP SCREEN. See Figure 4.2. If safeguards are in place, press **YES** on the keypad and proceed.

Figure 4.2
Wake-Up Screen



Main Run Screen Overview

The MAIN RUN SCREEN displays the crankshaft angle (in degrees), speed of the machine (in SPM), batch counter, stroke counter, mode of operation, and stop time (in milliseconds). See Figure 4.3.

The MAIN RUN SCREEN will be displayed whenever **ON** is selected on the program off/on selector switch.

Figure 4.3
Main Run Screen

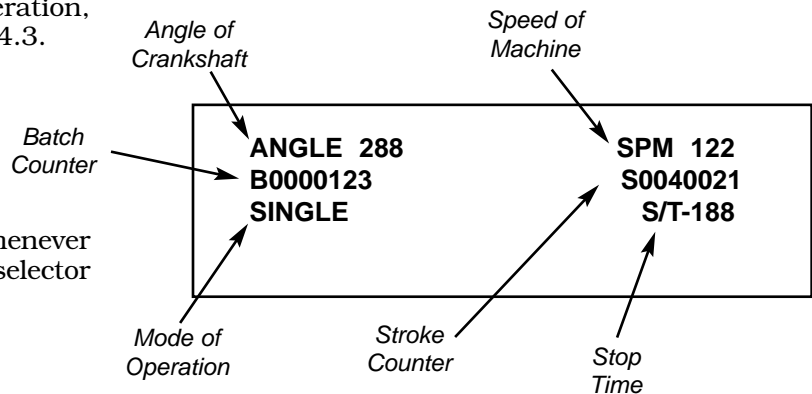

When **OFF** is selected on the mode selector switch, the control will not allow the machine to run and the CONTROL OFF SCREEN will be displayed. See Figure 4.4.

Figure 4.4
Control Off Screen

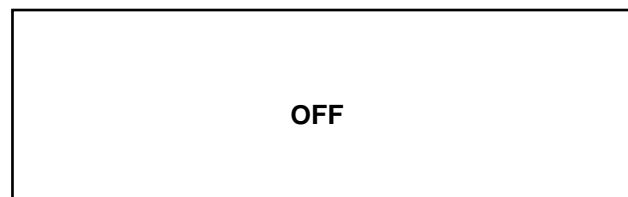

Programming Overview

The following sections outline the programming of the SSC1500 press brake control on a part-revolution-clutch press brake after installation of all components has been completed, and the *Power-Up Procedure* and *Main Run Screen Overview* sections of this manual have been read and understood.

MAIN PROGRAM SCREENS

The SSC1500 press brake control has two main programming screens from which you can access all of the programmable features of the control.

To program the control, select the **ON** position of the program off/on selector switch. The first MAIN PROGRAM SCREEN will be displayed.

On the screen, a pound symbol (#) will be next to one of the following program options from the list as shown. USER INPUTS is at the top of the list. See Figure 4.5.

Use ↓ and ↑ on the keypad to scroll through the program options. If you press ↓ when the pound symbol (#) is next to SYSTEM SETUP, the second MAIN PROGRAM SCREEN will be displayed. See Figure 4.6. If you press ↓ when the pound symbol (#) is next to PLS OUTPUT, the third MAIN PROGRAM SCREEN will be displayed. See Figure 4.7.

When the pound symbol (#) is next to the program option you want to edit, press **ENTER**. Once the new information is input and **ESC** is pressed, the display returns to the MAIN PROGRAM SCREEN. If incorrect information has been entered, return to the setting and reenter the correct information.

Each program option is described in detail on the following pages.

USER INPUTS	46-49
BRAKE MONITOR	50-52
COUNTERS	53-54
SYSTEM SETUP	55-64
ANGLE SETTINGS	65-66
TIMED SETTINGS	67
OPTIONAL MODES	68
PLS OUTPUT	69
AUXILIARY OUTPUT	70-71

Photo 4.1
Keypad/Display
With Program
Off/On Selector
Switch



Figure 4.5
First Main Program Screen

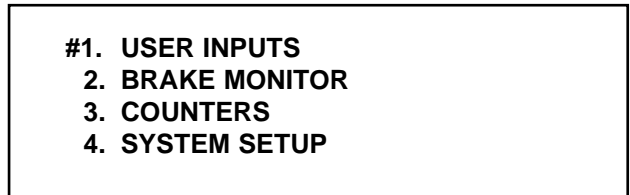

Figure 4.6
Second Main Program Screen

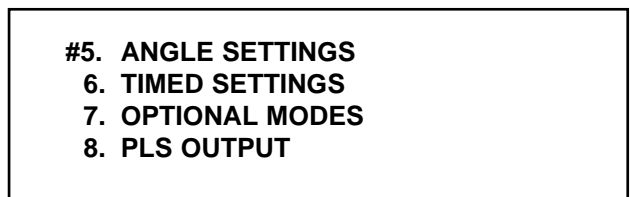
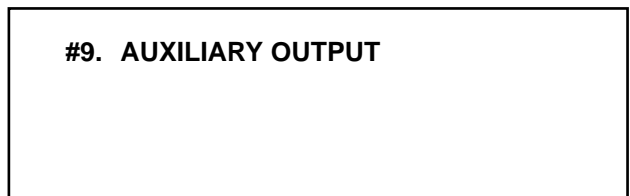

Figure 4.7
Third Main Program Screen



SECTION 4—PROGRAMMING

SSC1500 Part-Revolution Solid-State Control

USER INPUTS

The SSC1500 press brake control has eight (8) programmable user inputs (6 static-type inputs and 2 static- **or** cyclic-type inputs) that can be programmed for equipment monitoring or other user-defined functions. User Inputs 4 and 5 can be used as individual static inputs or they can be paired together.

Static-type means that when the inputs are set to be on, they are continuously monitoring for a change of state in the logic. When a change of state occurs, the input will go true, and the control will stop the machine. The static-type inputs are intended to diagnose fault conditions of auxiliary equipment specific to the machine, such as clutch/brake air pressure fault, counterbalance air pressure fault, and dual solenoid fault.

Cyclic-type means that when the inputs are set to be on, in addition to monitoring for a change of state in the logic, they are also monitoring for a change during the programmed Open and Close Angle window for each stroke.

There are three parameters that can be programmed for the six static-type inputs, and five parameters that can be programmed for the two static- or cyclic-type inputs. All inputs are 24-V DC current-sinking (NPN) inputs.

PROGRAMMABLE PARAMETERS FOR USER INPUTS 1-6

- 1. Logic:** This setting is used to change the logic that activates the input. The programming choices are N.O. (normally open), N.C. (normally closed), and OFF (disabled). Select one setting for each input.
- 2. Stop Type:** When the input is activated or goes true, the machine cycle will stop in one of two ways. E-STOP (emergency stop) will immediately stop the cycle in progress. T-STOP (top stop) will stop the cycle in progress at TDC (top dead center). Select the type of stop that is required for each input.
- 3. Message:** When the input is activated, a fault message is displayed. This fault message is assigned to the input according to its function. Figure 4.8 shows a list of fault messages that can be assigned to each input.

Figure 4.8
User Input Fault Messages

CLUTCH/BRAKE AIR FLT
CNTRBALANCE AIR FLT
DUAL SOLENOID FAULT
CLUTCH VALVE FAULT*
BRAKE VALVE FAULT*
LUBE FAULT
HIGH LUBE PRESSURE
LOW LUBE PRESSURE
LOW LUBE LEVEL
MAIN MOTOR OVERLOAD
RAM ADJ MTR OVERLOAD
LUBE MOTOR OVERLOAD
AUX MOTOR OVERLOAD
GUARD INTERLOCK OPEN
FRONT GUARD OPEN
REAR GUARD OPEN
LEFT SIDE GUARD OPEN
RIGHT SIDE GRD OPEN
FEEDER FAULT
LOAD MONITOR FAULT
SAFETY BLK INTERLOCK
SHUT HEIGHT FAULT
VAR SPEED DRIVE FLT
DIE PROTECTION FAULT**
SHORT FEED FAULT**
PART EJECTION FAULT**
STOCK BUCKLE FAULT**
END OF STOCK FAULT**
PILOT PIN FAULT**
PART INPUT #1**
PART INPUT #2**
PART INPUT #3**

*Only used with machines that have a split clutch and brake, and two dual valves have been furnished

**Messages typically used for die protection

(Continued on next page.)

HOW TO PROGRAM USER INPUTS 1-6

Select the **ON** position of the program off/on selector switch. One of the MAIN PROGRAM SCREENS will be displayed.

Use ↓ and ↑ on the keypad to scroll through the program options. Press **ENTER** when the pound symbol (#) is next to USER INPUTS. The first USER INPUTS SCREEN will be displayed. See Figure 4.9.

Use ↓ and ↑ on the keypad to scroll through the user inputs. If you press ↓ when the arrow symbol (>) is next to INPUT #4, the second USER INPUTS SCREEN will be displayed. See Figure 4.10. Press **ENTER** when the arrow symbol (>) is next to the user input you want to program. The PROGRAMMABLE PARAMETERS SCREEN shown in Figure 4.11 will be displayed.

Use ↓ and ↑ on the keypad to scroll through the programmable parameters. Press **ENTER** when the double arrow symbol (>>) is next to the parameter you want to program. A screen similar to the one shown in Figure 4.12 will be displayed.

Once you are in the programming screen of the parameter you want to program, use ↓ and ↑ on the keypad to reach the setting you desire for that parameter. Press **ENTER** to finish.

Press **ESC** to return to the MAIN PROGRAM SCREEN.

Note: The appropriate user input terminals in the control box must be wired into so they correspond to the assigned fault messages. If the order of the messages is changed or if other fault messages are assigned, the connections to the terminal strip must also be rearranged to reflect the changes.

USER INPUTS 4 and 5 (When paired together)

For additional reliability, User Inputs 4 and 5 can be paired together to monitor two devices linked together, such as two contacts on a guard interlock switch. When the inputs are paired together, the control will look for both inputs to change state at the same time. If they do, the control will stop the press brake and the programmed fault message for the pair will be displayed. If they do not, the same will happen, but then a fatal fault will occur (see page 74) with the message “invalid pair signals” displayed.

To pair the inputs together, the logic for User Input 4 must be set to either N.O.(PAIR) for normally open or N.C.(PAIR) for normally closed. The stop type and fault message for the pair are programmed using User Input 4 as well.

Note: When the inputs are paired together, you will not be able to make programming changes to User Input 5 until the inputs are unpaired by changing the logic for User Input 4 to OFF, N.O., or N.C.

Figure 4.9
First User Inputs Screen

```
>Input #1
  Input #2
  Input #3
  Input #4 (Pair)
```

Figure 4.10
Second User Inputs Screen

```
>Input #5 (Pair)
  Input #6
  Input #7 (Cyclic)
  Input #8 (Cyclic)
```

Figure 4.11
Programmable Parameters

```
>>Logic
  Stop Type
  Message
```

Figure 4.12
Example of a Programming Screen

```
PROGRAMMING:
Input #1
Logic
OFF
```

(Continued on next page.)

SECTION 4—PROGRAMMING

SSC1500 Part-Revolution Solid-State Control

PROGRAMMABLE PARAMETERS FOR USER INPUTS 7-8

- 1. Logic:** This setting is used to change the logic that activates the input. The programming choices are N.O. (normally open), N.C. (normally closed), and OFF (disabled). Select one setting for each input.
- 2. Stop Type:** When the input is activated or goes true, the machine cycle will stop in one of two ways. E-STOP (emergency stop) will immediately stop the cycle in progress. T-STOP (top stop) will stop the cycle in progress at TDC (top dead center). Select the type of stop that is required for each input.
- 3. Message:** When the input is activated, a fault message is displayed. This fault message is assigned to the input according to its function. Figure 4.13 shows a list of fault messages that can be assigned to each input.
- 4. Open Angle:** This angle setting is used to activate the window during which the control will look for a change of state of the input. The setting ranges from 0° to 359°. If this setting and the Close angle are both set to 0°, the input will be a static input.
- 5. Close Angle:** This angle setting is used to deactivate the window during which the control will look for a change of state of the input. The setting ranges from 0° to 359°. If this setting and the Open angle are both set to 0°, the input will be a static input.

Figure 4.13
User Input Fault Messages

CLUTCH/BRAKE AIR FLT
CNTRBALANCE AIR FLT
DUAL SOLENOID FAULT
CLUTCH VALVE FAULT*
BRAKE VALVE FAULT*
LUBE FAULT
HIGH LUBE PRESSURE
LOW LUBE PRESSURE
LOW LUBE LEVEL
MAIN MOTOR OVERLOAD
RAM ADJ MTR OVERLOAD
LUBE MOTOR OVERLOAD
AUX MOTOR OVERLOAD
GUARD INTERLOCK OPEN
FRONT GUARD OPEN
REAR GUARD OPEN
LEFT SIDE GUARD OPEN
RIGHT SIDE GRD OPEN
FEEDER FAULT
LOAD MONITOR FAULT
SAFETY BLK INTERLOCK
SHUT HEIGHT FAULT
VAR SPEED DRIVE FLT
DIE PROTECTION FAULT**
SHORT FEED FAULT**
PART EJECTION FAULT**
STOCK BUCKLE FAULT**
END OF STOCK FAULT**
PILOT PIN FAULT**
PART INPUT #1**
PART INPUT #2**
PART INPUT #3**

*Only used with machines that have a split clutch and brake, and two dual valves have been furnished

**Messages typically used for die protection

(Continued on next page.)

HOW TO PROGRAM USER INPUTS 7-8

Select the **ON** position of the program off/on selector switch. One of the MAIN PROGRAM SCREENS will be displayed.

Use ↓ and ↑ on the keypad to scroll through the program options. Press **ENTER** when the pound symbol (#) is next to USER INPUTS. The first USER INPUTS SCREEN will be displayed. See Figure 4.14.

Use ↓ and ↑ on the keypad to scroll through the user inputs. If you press ↓ when the arrow symbol (>) is next to Input #4, the second USER INPUTS SCREEN will be displayed. See Figure 4.15. Press **ENTER** when the arrow symbol (>) is next to user input #7 or #8. The first PROGRAMMABLE PARAMETERS SCREEN shown in Figure 4.16 will be displayed.

Use ↓ and ↑ on the keypad to scroll through the programmable parameters. If you press ↓ when the double arrow symbol (>>) is next to Open Angle, the second PROGRAMMABLE PARAMETERS SCREEN will be displayed. See Figure 4.17. Press **ENTER** when the double arrow symbol (>>) is next to the parameter you want to program. A screen similar to the one shown in Figure 4.18 will be displayed.

Once you are in the programming screen of the parameter you want to program, use ↓ and ↑ on the keypad to reach the setting you desire for that parameter. Use the numeric keypad for setting the Open and Close Angles. Press **ENTER** to finish.

Press **ESC** when finished to return to the MAIN PROGRAM SCREEN.

Note: The appropriate user input terminals in the control box must be wired so they correspond to the assigned fault messages. If the order of the messages is changed or if other fault messages are assigned, the connections to the terminal strip must also be rearranged to reflect the changes.

Figure 4.14
First User Inputs Screen

```
>Input #1
Input #2
Input #3
Input #4 (Pair)
```

Figure 4.15
Second User Inputs Screen

```
Input #5 (Pair)
Input #6
>Input #7 (Cyclic)
Input #8 (Cyclic)
```

Figure 4.16
First Programmable Parameters Screen

```
>>Logic
Stop Type
Message
Open Angle
```

Figure 4.17
Second Programmable Parameters Screen

```
>>Close Angle
```

Figure 4.18
Example of a Programming Screen

```
PROGRAMMING:
Input #7 (Cyclic)
Logic
OFF
```

SECTION 4—PROGRAMMING

SSC1500 Part-Revolution Solid-State Control

BRAKE MONITOR

The SSC1500 press brake control has a time-based brake monitor with programmable warning and fault setpoints. The control also includes an STM (stop-time measurement) test. This test is used on the downstroke (usually at 90°) for establishing proper safety distance when applying two-hand control or a light curtain as the safeguarding device. The test is also used on the upstroke (at the appropriate angle that makes the machine stop at top) to calculate the warning and fault setpoints for the brake monitor.

Every time the machine stops, the control measures the time between when the valve deenergizes and when the resolver no longer detects motion. This is the actual stopping time of the press brake. The warning and fault setpoints are automatically compared to this stopping time, and will alert the operator if the stopping time is beyond either of these setpoints.

If the stopping time is greater than only the warning setpoint, a message will be displayed for five (5) seconds on the screen, and then it will disappear. The press will not operate during these five seconds. If the stopping time is greater than the fault setpoint, the press will become inoperable, and a message will be displayed on the screen that will stay there until you press **ENTER** on the keypad to reset the control, acknowledging the fault message.

Brake monitor warnings and faults can be caused by several factors. Brake deterioration is one of the main factors that will increase the machine's stopping time. If you have a variable-speed drive, running the machine at higher speeds will increase the stopping time due to the increased inertia. The stopping time may also increase if you use a heavier die, for the same reason. If you have a counterbalance system, the stopping time may increase if the air pressure is not adjusted properly based on the upper die weight. Clogs or particles in the air line or in the valve muffler may increase stopping time. Air pressure variance can also affect the stopping time of the machine.

If you are experiencing warning or fault messages more frequently, inspect the machine and perform any necessary repairs to improve the machine's stopping ability. For example, if your brake is deteriorating, it may need a new lining, or you may need to tighten or replace the engaging spring(s) on it. **DO NOT** increase the warning and fault setpoints just to avoid nuisance stops. You will also need to run a new series of STM tests on the downstroke to establish the new safety distance. You will then need to remount or move your light curtain or palm buttons (if they are used for two-hand control) further away from the point of operation according to the new safety distance.

HOW TO RUN AN STM (STOP-TIME MEASUREMENT) TEST

Select the **ON** position of the program off/on selector switch. One of the MAIN PROGRAM SCREENS will be displayed.

On the MAIN PROGRAM SCREEN, use ↓ and ↑ on the keypad to scroll through the program options. Press **ENTER** when the pound symbol (#) is next to BRAKE MONITOR. The security code screen will be displayed. See Figure 4.19. You will be prompted to enter the security code. See page 60 for information on programming the security code.

Press **ESC** to stop and return to the MAIN PROGRAM SCREEN. Press **BKSP** to backspace or press **CLR** to delete the entry and start over. Press **ENTER** when finished. After the correct security code has been entered, the BRAKE MONITOR SCREEN will be displayed. See Figure 4.20.

Figure 4.19
Security Code Screen

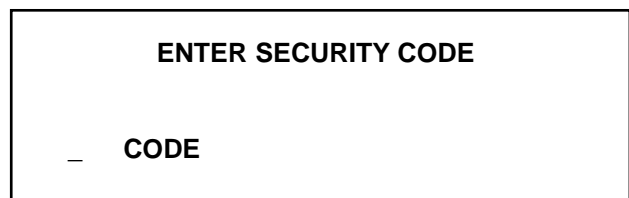
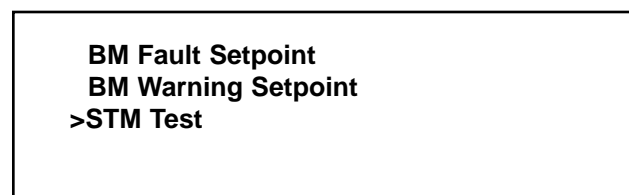

Figure 4.20
Brake Monitor Screen



(Continued on next page.)

HOW TO RUN AN STM (STOP-TIME MEASUREMENT) TEST (continued)

Use ↓ and ↑ on the keypad to scroll up and down. Press **ENTER** when the arrow symbol (>) is next to STM Test. The STM Test Screen will be displayed. See Figure 4.21.

Use the keypad to enter the angle at which the STM will be taken. Press **ENTER** when finished. You will be prompted to check for TDC (top dead center), and then to cycle the machine.

Follow the prompt and visually make sure the crankshaft is at TDC. If it is not at TDC, press **ESC** to exit and select the **OFF** position of the program off/on selector switch. Then either inch or single stroke the machine to get it to top, then cycle the machine. After the machine makes a partial stroke, the screen will display the stopping time in milliseconds and the safety distance in inches (if the test was done on the downstroke). See Figure 4.22. Press **ESC** to exit and select the **OFF** position of the program off/on selector switch. Then either inch or single stroke the machine to return to TDC.

To run more than one STM, select the **ON** position of the program off/on selector switch. The pound symbol (#) should still be next to BRAKE MONITOR. Press **ENTER**. If you have not waited more than five minutes since the last STM test, you will not have to enter the security code.

The arrow symbol (>) should still be next to STM Test. Press **ENTER**. When the angle at which the STM will be taken is correct, press **ENTER**. Follow the display prompts and cycle the machine. After the results of the test have been displayed, return the crankshaft to TDC. Repeat this process until the desired number of tests are complete.

Press **ESC** when finished to return to the BRAKE MONITOR SCREEN. Press **ESC** again to return to the MAIN PROGRAM SCREEN.

Figure 4.21
STM Test Screen

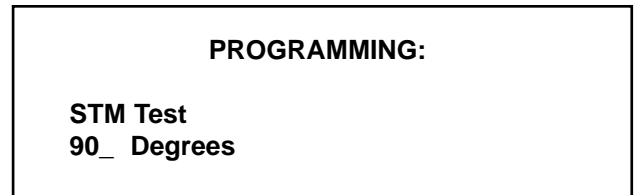
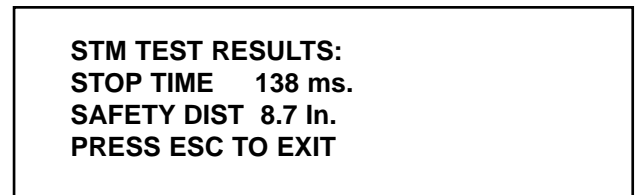

Figure 4.22
Sample of the STM Test Results Screen



(Continued on next page.)

SECTION 4—PROGRAMMING

SSC1500 Part-Revolution Solid-State Control

HOW TO CALCULATE THE BRAKE MONITOR WARNING AND FAULT SETPOINTS

To determine the brake monitor warning and fault setpoints using the STM test feature, you need to determine the proper STM angle so the stop signal is given on the upstroke, and the angle stop point makes the machine stop at TDC (top dead center). This angle is usually between 200° and 300°. You may have to take several STM tests before you get the correct angle setting for your machine, since this setting is determined by trial and error. A good angle to start with is 270°. If the machine stops before TDC, a higher STM angle setting is required. Add the number of degrees the machine stopped short of TDC to the STM angle setting. If the machine stops beyond TDC, a lower STM angle setting is required. Subtract the number of degrees the machine went over TDC from the STM angle setting. Once you get the correct STM angle setting and your machine is stopping at TDC, you are ready to calculate the warning and fault setpoints for the brake monitor.

Take and record several readings (at least ten) of the stopping time using the STM feature and the STM angle setting that makes the machine stop at TDC. If any of your readings are excessively high compared to the rest of the readings, disregard them and use the next highest reading. After taking several readings, use the longest time and multiply it by 1.05 (105%) to establish the warning setpoint. To establish the fault setpoint, multiply the highest reading by 1.10 (110%).

HOW TO PROGRAM THE BRAKE MONITOR WARNING AND FAULT SETPOINTS

To adjust the warning setpoint:

Use ↓ and ↑ on the keypad to scroll up and down. Press **ENTER** when the arrow symbol (>) is next to the BM Warning Setpoint. The BM Warning Setpoint Screen will be displayed. See Figure 4.23.

Use the keypad to enter the time setting. Press **ENTER** when finished to return to the BRAKE MONITOR SCREEN.

To adjust the fault setpoint:

Use ↓ and ↑ on the keypad to scroll up and down. Press **ENTER** when the arrow symbol (>) is next to the BM Fault Setpoint. The BM Fault Setpoint Screen will be displayed. See Figure 4.24.

Use the keypad to enter the time setting. Press **ENTER** when finished to return to the BRAKE MONITOR SCREEN.

Press **ESC** when finished to return to the MAIN PROGRAM SCREEN.

Figure 4.23
Warning Setpoint Screen

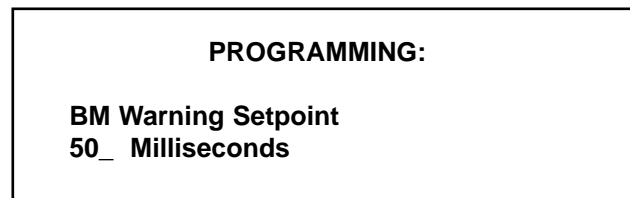
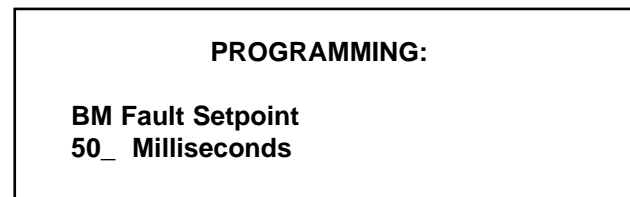

Figure 4.24
Fault Setpoint Screen



COUNTERS

The SSC1500 press brake control has stroke and batch counters that can be used for die maintenance, quality control checks, or part bin exchanges. These counters have a programmable preset that will signal the machine to top stop when the preset is reached. The preset has a maximum of 9,999,999 strokes. There is also a total counter, which has security code protection.

When either the batch counter or stroke counter has reached its preset value and **BATCH COUNT EXPIRED** or **STROKE COUNT EXPIRED** is displayed, the fault message can be cleared and the counter can be reset by touching **ENTER** on the keypad.

HOW TO PROGRAM THE COUNTERS

Select the **ON** position of the program off/on selector switch. One of the MAIN PROGRAM SCREENS will be displayed.

On the MAIN PROGRAM SCREEN, use ↓ and ↑ on the keypad to scroll through the program options. Press **ENTER** when the pound symbol (#) is next to COUNTERS. The first COUNTER PROGRAM SCREEN will be displayed. See Figure 4.25. If you press ↓ when the arrow symbol is next to Stroke Preset, the second COUNTER PROGRAM SCREEN will be displayed. See Figure 4.26.

To enter a batch preset:

Use ↓ and ↑ on the keypad to scroll up and down. Press **ENTER** when the arrow symbol (>) is next to Batch Preset. You will see the BATCH PRESET SCREEN. See Figure 4.27.

After you have entered a preset, press **ENTER** to finish. This will bring you back to the COUNTER PROGRAM SCREEN.

To clear the batch counter:

Use ↓ and ↑ on the keypad to scroll up and down. Press **ENTER** when the arrow symbol (>) is next to Batch Clear. You will see the CLEAR BATCH SCREEN. See Figure 4.28.

Press **YES** to confirm and the counter will be cleared.

Press **NO** to return to the COUNTER PROGRAM SCREEN.

Figure 4.25
First Counter Program Screen



Figure 4.26
Second Counter Program Screen



Figure 4.27
Batch Preset Screen

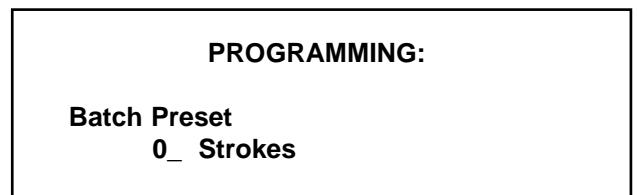
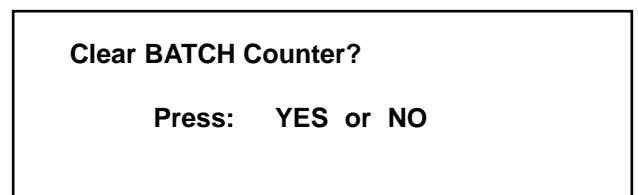

Figure 4.28
Clear Batch Screen



(Continued on next page.)

SECTION 4—PROGRAMMING

SSC1500 Part-Revolution Solid-State Control

HOW TO PROGRAM THE COUNTERS (continued)

To enter a stroke preset:

Use ↓ and ↑ on the keypad to scroll up and down. Press **ENTER** when the arrow symbol (>) is next to Stroke Preset. You will see the STROKE PRESET SCREEN. See Figure 4.29.

After you have entered a preset, press **ENTER** to finish. This will bring you back to the COUNTER PROGRAM SCREEN.

To clear the stroke counter:

Use ↓ and ↑ on the keypad to scroll up and down. Press **ENTER** when the arrow symbol (>) is next to Stroke Clear. You will see the CLEAR STROKE SCREEN. See Figure 4.30.

Press **YES** to confirm and the counter will be cleared.

Press **NO** to return to the COUNTER PROGRAM SCREEN.

To clear or view the total counter:

Use ↓ and ↑ on the keypad to scroll up and down. Press **ENTER** when the arrow symbol (>) is next to Total Clear. The Security Code Screen will be displayed. See Figure 4.31. You will be prompted to enter the security code.

Press **ESC** to stop and return to the COUNTERS PROGRAM SCREEN. Press **BKSP** to backspace or press **CLR** to delete the entry and start over. Press **ENTER** when finished. After the correct security code has been entered, you will see the CLEAR TOTAL SCREEN which also displays the total counter. See Figure 4.32.

To only view the counter and not clear it, press **NO** to return to the COUNTER PROGRAM SCREEN.

To clear the total counter, press **YES** to confirm and the counter will be cleared.

Press **ESC** when finished to return to the MAIN PROGRAM SCREEN.

Figure 4.29
Stroke Preset Screen

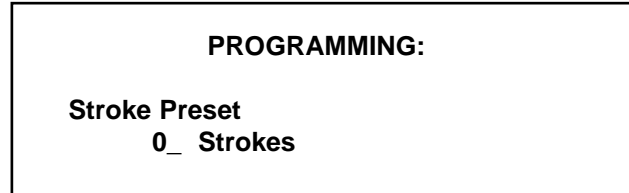

Figure 4.30
Clear Stroke Screen

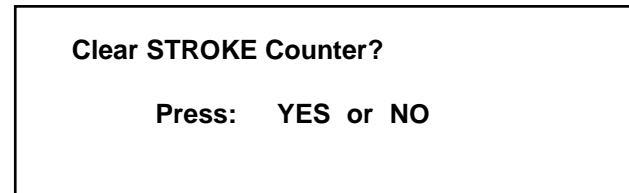

Figure 4.31
Security Code Screen

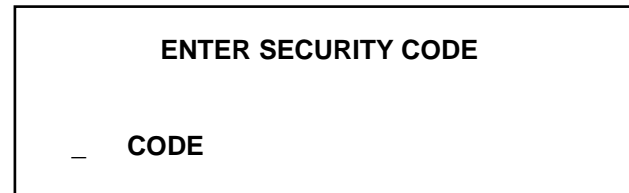
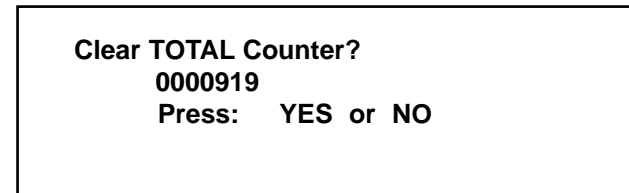

Figure 4.32
Clear Total Screen



SYSTEM SETUP

The SSC1500 press brake control has a system setup screen that is used to automatically zero the resolver, set the motion reference threshold, automatically set the sync switch position, program the speed-change solenoid valve, restore the factory default settings, program the security code, program the network settings, set the SPM range, turn on or off the angle display, and turn on or off Spanish display text.

AUTOMATICALLY ZERO THE RESOLVER

If the resolver is mounted correctly, with the machine at TDC (top dead center) and the keyway facing up and perpendicular to the base, it should be very close to its physical 0° point. However, since it is most likely a few degrees off, the resolver will be automatically zeroed, which will reset it to 0°, regardless of where its physical 0° point is located. This will provide the control with more accurate angle settings and readings.

MOTION REFERENCE THRESHOLD

The motion reference threshold is the amount of time the control takes to see motion when the press is stroked. It is used to detect chain breakage, sprocket failure, or uncoupling of the resolver.

When a reference cycle is run, the control measures the amount of time the machine takes to go from 0 to 4 SPM (strokes per minute). This is because any speed less than 4 SPM is not considered normal motion by the control. This number is then doubled to allow for inconsistencies of the machine. Every time a stroke is started, the control looks for motion within this amount of time. If motion is not seen within this amount of time, a fault message will be displayed.

SYNC SWITCH

The sync switch is an optical pulser inside the resolver that provides redundancy in the resolver. It monitors and crosschecks for mechanical or electronic failures within the resolver.

The pulser has a physical cam with a 30° window that is set to activate at 75° and deactivate at 105°, in relation to the resolver's physical 0° point (mounted with the keyway up, perpendicular to the base). The sync switch should not come on between 330° and 30°. If it does, the reference cycle will fail, and a fault message will be displayed. The keyway on the resolver will have to be rotated so the sync switch does not come on between 330° and 30°.

When a reference cycle is run, the pulser will record the on and off angles of the sync switch. These angles, called sync on and sync off, will then be displayed on the screen. On every subsequent stroke of the press, the control will watch for the sync switch to come on and off at the same angles, +/- 2.5°.

SPEED-CHANGE SOLENOID VALVE

Two-speed air-clutch press brakes have a second speed-change solenoid valve that controls which clutch the air is sent to. If your machine runs in low speed when this valve is on, the programmed setting should be VALVE ON=LOW. If your machine runs in high speed when this valve is on, the programmed setting should be VALVE ON=HIGH.

Note: Mechanical-friction-clutch and single-speed air-clutch press brakes do not have this second valve, so the programmed setting should be VALVE DISABLED (which is the factory default setting).

SECURITY CODE

The security code is user-programmed up to a 4-digit number. This code is required to enter the BRAKE MONITOR, SYSTEM SETUP, ANGLE SETTINGS, TIMED SETTINGS, and AUXILIARY OUTPUT SCREENS. It is also required when the total counter is cleared and when the factory default settings are restored.

NETWORK SETTINGS

The network settings are used to configure the control for networking. In order to network the control, the optional networking assembly, part No. FTL314, is required. The networking assembly consists of a TCP/IP (Transmission Control Protocol/Internet Protocol) modem card with mounting plate, a 5' cable, and a CD with a data collection program. The modem card and cable plug into the P3 network port on the SSC1500 control module. Use of the network modem will provide data collection and viewing of current data via a standard Web browser such as Internet Explorer or Netscape Navigator. The current status of the press brake and what the control is doing can be monitored.

(Continued on next page.)

SECTION 4—PROGRAMMING

SSC1500 Part-Revolution Solid-State Control

NETWORK SETTINGS (continued)

The data collection software that is furnished with the networking assembly will save data to a flat text file. Most any database, spreadsheet, or word processing program such as Microsoft Access, Microsoft Excel, dBASE, or Paradox can import the information. This software program can accommodate up to 32 machines. Opening the program again will accommodate 32 more machines.

The following information is available for viewing and data collection; it can be arranged to accommodate your needs.

- Batch counter
- Batch preset
- Brake monitor fault setpoint
- Brake monitor status
- Current mode
- Date and time
- SPM
- Stop time
- Stroke counter
- Stroke preset
- Total counter

Note: Your network administrator or an experienced IT (information technology) person will be required to program the network settings and install the networking assembly.

SPM RANGE

The SPM range should be set according to the speed of the machine in SPM (strokes per minute). The three choices are low (0-30), medium (31-150), and high (151+). This will allow the control to react and process information appropriately in relation to the speed of the machine. Slower machines may need extra time for operations to occur while faster machines usually require tighter settings.

LIGHT CURTAIN INPUT

The SSC1500 press brake control is factory set to two N.O. (normally open) light curtain inputs (closed in the powered-up “green” state). These inputs are Terminals P8-14 (LC CT #1) and P8-15 (LC CT #2) on the SSC1500 control module. The inputs can also be set for one N.O. (normally open) and one N.C. (normally closed). For more information, please refer to the connection diagram on page 6 and the wiring schematics included with the control.

ANGLE DISPLAY

The angle display is an optional unit (Part No. FTL055) that shows the angular position of the crankshaft both graphically (with red LEDs in a circle) and numerically (with a large, red, three-digit LED display). The angle display should be mounted where it is easily viewed to help with setup, removal of stuck workpieces, or for assistance during emergency extraction procedures.

SPANISH

When this setting is turned on, all of the display text will be in Spanish.

(Continued on next page.)

HOW TO RUN THE REFERENCE CYCLE

Select the **ON** position of the program off/on selector switch. One of the MAIN PROGRAM SCREENS will be displayed.

On the MAIN PROGRAM SCREEN, use ↓ and ↑ on the keypad to scroll through the program options. Press **ENTER** when the pound symbol (#) is next to SYSTEM SETUP. The security code screen will be displayed. See Figure 4.33. You will be prompted to enter the security code.*

Press **ESC** to stop and return to the MAIN PROGRAM SCREEN. Press **BKSP** to backspace or press **CLR** to delete the entry and start over. Press **ENTER** when finished.

After the correct security code has been entered, the first SYSTEM SETUP SCREEN will be displayed. See Figure 4.34.

Use ↓ and ↑ on the keypad to scroll up and down. Press **ENTER** when the arrow symbol (>) is next to Reference Cycle. The REFERENCE CYCLE INSTRUCTIONS SCREEN will be displayed. See Figure 4.35. Press **YES** to run a reference cycle, then cycle the machine. A screen similar to the one shown in Figure 4.36 will be displayed.

Press **ESC** when finished to return to the SYSTEM SETUP SCREEN. Press **ESC** again to return to the MAIN PROGRAM SCREEN.

Figure 4.33
Security Code Screen

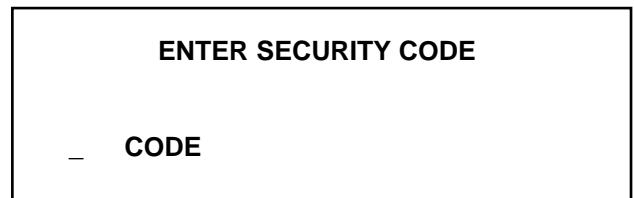

Figure 4.34
First System Setup Screen

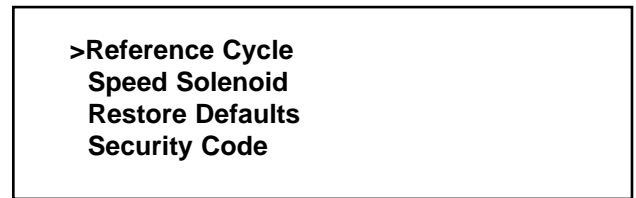
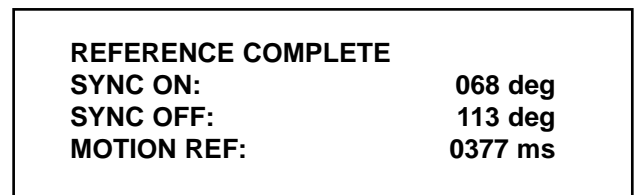

Figure 4.35
Reference Cycle Instructions Screen



Figure 4.36
Sample of Completed Reference Cycle Screen



*The factory default security code is 0. With this code, you can proceed past the security code screen by pressing **0** and then **ENTER** on the keypad, or by simply pressing **ENTER**.

To program your own security code, see page 60. If at any time you forget your security code, call the factory at 1-800-922-7533 or (815) 874-7891 to receive the master security code.

(Continued on next page.)

SECTION 4—PROGRAMMING

SSC1500 Part-Revolution Solid-State Control

HOW TO PROGRAM THE SPEED-CHANGE SOLENOID VALVE

Select the **ON** position of the program off/on selector switch. One of the MAIN PROGRAM SCREENS will be displayed.

On the MAIN PROGRAM SCREEN, use ↓ and ↑ on the keypad to scroll through the program options. Press **ENTER** when the pound symbol (#) is next to SYSTEM SETUP. The security code screen will be displayed. See Figure 4.37. You will be prompted to enter the security code.

Press **ESC** to stop and return to the MAIN PROGRAM SCREEN. Press **BKSP** to backspace or press **CLR** to delete the entry and start over. Press **ENTER** when finished.

After the correct security code has been entered, the first SYSTEM SETUP SCREEN will be displayed. See Figure 4.38.

Use ↓ and ↑ on the keypad to scroll up and down. Press **ENTER** when the arrow symbol (>) is next to Speed Solenoid. The SPEED SOLENOID SCREEN will be displayed. See Figure 4.39.

Use ↓ and ↑ on the keypad to reach the setting you desire. Press **ENTER** to finish.

Press **ESC** when finished to return to the MAIN PROGRAM SCREEN.

Figure 4.37
Security Code Screen

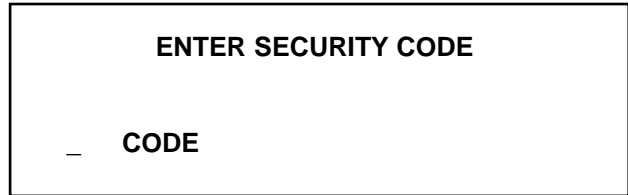

Figure 4.38
First System Setup Screen

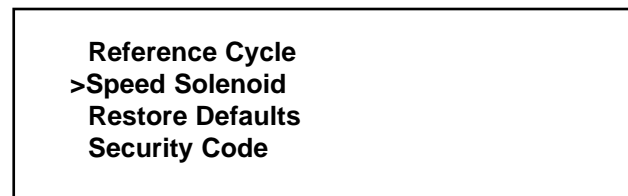
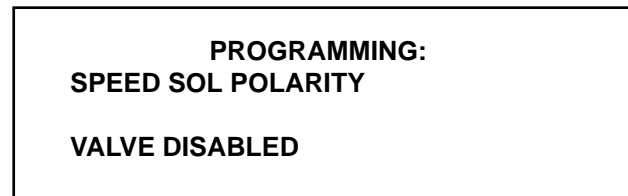

Figure 4.39
Speed Solenoid Screen



(Continued on next page.)

HOW TO RESTORE FACTORY DEFAULT SETTINGS

Select the **ON** position of the program off/on selector switch. One of the MAIN PROGRAM SCREENS will be displayed.

On the MAIN PROGRAM SCREEN, use ↓ and ↑ on the keypad to scroll through the program options. Press **ENTER** when the pound symbol (#) is next to SYSTEM SETUP. The security code screen will be displayed. See Figure 4.40. You will be prompted to enter the security code.

Press **ESC** to stop and return to the MAIN PROGRAM SCREEN. Press **BKSP** to backspace or press **CLR** to delete the entry and start over. Press **ENTER** when finished.

After the correct security code has been entered, the first SYSTEM SETUP SCREEN will be displayed. See Figure 4.41.

Use ↓ and ↑ on the keypad to scroll up and down. Press **ENTER** when the arrow symbol (>) is next to Restore Defaults. The RESTORE DEFAULTS SCREEN will be displayed. See Figure 4.42.

Press **YES** to confirm and the factory default settings will be restored. See pages 72-73 for the factory default settings.

Press **ESC** when finished to return to the MAIN PROGRAM SCREEN.

Figure 4.40
Security Code Screen

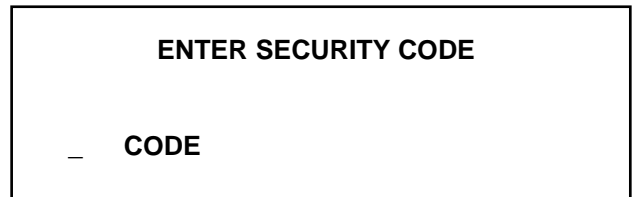

Figure 4.41
First System Setup Screen

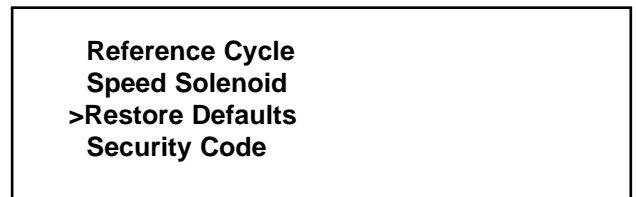
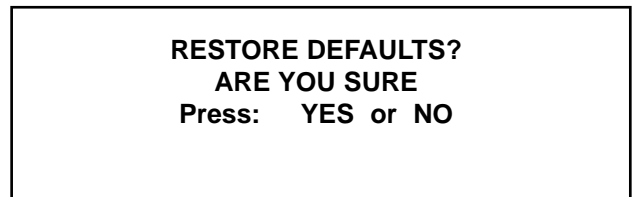

Figure 4.42
Restore Defaults Screen



(Continued on next page.)

SECTION 4—PROGRAMMING

SSC1500 Part-Revolution Solid-State Control

HOW TO PROGRAM THE SECURITY CODE

Select the **ON** position of the program off/on selector switch. One of the MAIN PROGRAM SCREENS will be displayed.

On the MAIN PROGRAM SCREEN, use ↓ and ↑ on the keypad to scroll through the program options. Press **ENTER** when the pound symbol (#) is next to SYSTEM SETUP. The security code screen will be displayed. See Figure 4.43. You will be prompted to enter the security code.

Press **ESC** to stop and return to the MAIN PROGRAM SCREEN. Press **BKSP** to backspace or press **CLR** to delete the entry and start over. Press **ENTER** when finished.

After the correct security code has been entered, the first SYSTEM SETUP SCREEN will be displayed. See Figure 4.44.

Use ↓ and ↑ on the keypad to scroll up and down. Press **ENTER** when the arrow symbol (>) is next to Security Code. The SECURITY CODE PROGRAM SCREEN will be displayed. See Figure 4.45.

Use the keypad to enter a security code up to a 4-digit number. Press **ENTER** when finished.

Press **ESC** when finished to return to the MAIN PROGRAM SCREEN.

Figure 4.43—Security Code Screen

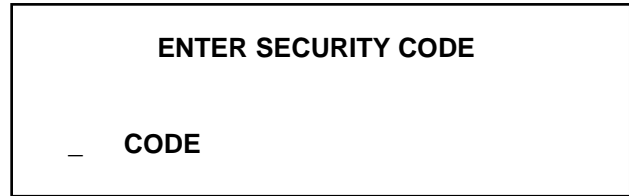

Figure 4.44—First System Setup Screen

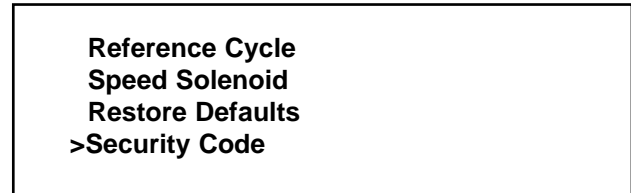
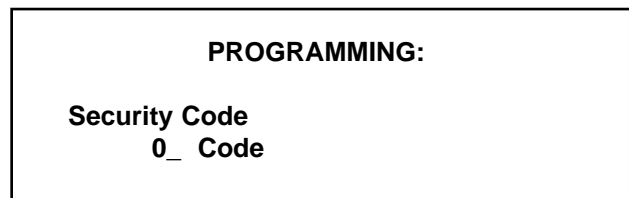

Figure 4.45—Security Code Program Screen



(Continued on next page.)

PROGRAMMABLE PARAMETERS FOR THE NETWORK SETTINGS

1. **NAME:** This setting is used to assign a unique name to the SSC1500 control or machine that it is on. This name must be unique on the network to which you are connecting the control.

2. **WORK GROUP:** This setting can be used to include the SSC1500 control in a particular workgroup of devices on your network. When this is done, the SSC1500 control will show up (with the name you assigned it) within that workgroup when you browse your network.

Note: If you do not have a DNS (Domain Name System) server, this parameter does not need to be programmed.

3. **ADDRESS:** This setting is used to enter the unique IP (Internet Protocol) address assigned to the SSC1500 control. The IP address must consist of four sets of numbers, separated by periods; e.g., 127.0.0.1. The IP address can range from 0.0.0.0 to 255.255.255.255.

Note: If DHCP is used (see MODE below), this parameter does not need to be programmed.

4. **MASK:** This setting is used to enter the subnet mask. The subnet mask is a transformation performed on the IP address that enables the network administrators to create subnets, which are virtual subunits of the physical network. The subnet mask must consist of four sets of numbers, separated by periods; e.g., 255.255.255.0. The subnet mask can range from 0.0.0.0 to 255.255.255.255.

Note: If DHCP is used (see MODE below), this parameter does not need to be programmed.

5. **MODE:** This setting is used to select the type of IP address that is used. The programming choices are STATIC and DHCP. Static is a permanent IP address that is assigned to a device in a TCP/IP (Transmission Control Protocol/Internet Protocol) network. DHCP, which stands for Dynamic Host Configuration Protocol, is a protocol that enables a TCP/IP device on your network to receive a temporary IP address from another device on your network automatically.

HOW TO PROGRAM THE NETWORK SETTINGS

Note: Your network administrator or an experienced IT (information technology) person will be required to program the network settings.

Select the **ON** position of the program off/on selector switch. One of the MAIN PROGRAM SCREENS will be displayed.

On the MAIN PROGRAM SCREEN, use ↓ and ↑ on the keypad to scroll through the program options. Press **ENTER** when the pound symbol (#) is next to SYSTEM SETUP. The security code screen will be displayed. See Figure 4.46. You will be prompted to enter the security code.

Press **ESC** to stop and return to the MAIN PROGRAM SCREEN. Press **BKSP** to backspace or press **CLR** to delete the entry and start over. Press **ENTER** when finished.

After the correct security code has been entered, the first SYSTEM SETUP SCREEN will be displayed. See Figure 4.47. Press ↓ when the arrow (>) symbol is next to Security Code and the second SYSTEM SETUP SCREEN will be displayed. See Figure 4.48.

Figure 4.46—Security Code Screen

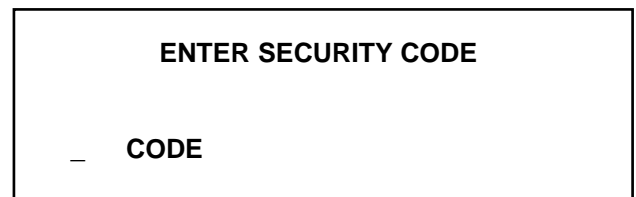

Figure 4.47—First System Setup Screen

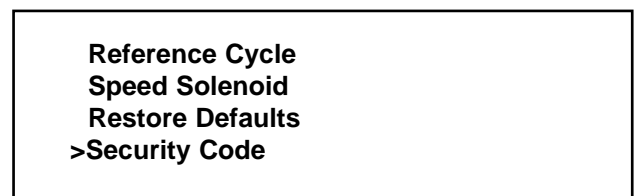
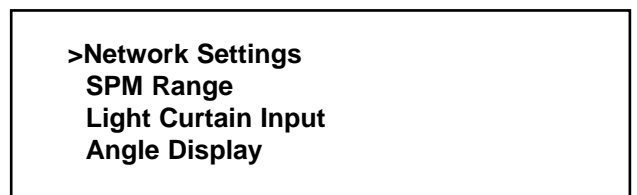

Figure 4.48—Second System Setup Screen



(Continued on next page.)

SECTION 4—PROGRAMMING

SSC1500 Part-Revolution Solid-State Control

HOW TO PROGRAM THE NETWORK SETTINGS (continued)

Use ↓ and ↑ on the keypad to scroll up and down. Press **ENTER** when the arrow symbol (>) is next to Network Settings. The first NETWORK PARAMETERS SCREEN shown in Figure 4.49 will be displayed.

Use ↓ and ↑ on the keypad to scroll through the programmable parameters. If you press ↓ when the double arrow symbol (>>) is next to MASK, the second NETWORK PARAMETERS SCREEN will be displayed. See Figure 4.50. Press **ENTER** when the double arrow symbol (>>) is next to the parameter you want to program. A screen similar to the one shown in Figure 4.51 will be displayed.

Once you are in the programming screen of the parameter you want to program, use the keypad to program the setting you desire for that parameter. To enter letters when programming the Name and Work Group, see Figure 4.52. If an underscore is needed, use the blank key above the **YES** key. Use ↓ and ↑ on the keypad for setting the Mode. Press **ENTER** to finish.

Press **ESC** when finished to return to the MAIN PROGRAM SCREEN.

Figure 4.49—First Network Parameters Screen

```
>>NAME
   WORK GROUP
   ADDRESS
   MASK
```

Figure 4.50—Second Network Parameters Screen

```
>>MODE
```

Figure 4.51—Example of a Programming Screen

```
NAME

MYNAME_
```

Figure 4.52—Keypad Numbers and Corresponding Letters

2	3	4	5	6	7	8	9
A	D	G	J	M	P	T	W
B	E	H	K	N	Q	U	X
C	F	I	L	O	R	V	Y
Blank key = underscore					S		Z

The keypad numbers and corresponding letters are the same as those of the keypad on a telephone. To enter a letter, push the corresponding number key until the letter you want appears. Once you get the letter you want, wait for about 2 seconds, and then the cursor will move to the right. You will then be able to input the next letter.

Press **ESC** to stop and return to the NETWORK PARAMETERS SCREEN. Press **BKSP** to backspace or press **CLR** to delete the entry and start over. Press **ENTER** when finished.

(Continued on next page.)

HOW TO PROGRAM THE SPM RANGE

Select the **ON** position of the program off/on selector switch. One of the MAIN PROGRAM SCREENS will be displayed.

On the MAIN PROGRAM SCREEN, use ↓ and ↑ on the keypad to scroll through the program options. Press **ENTER** when the pound symbol (#) is next to SYSTEM SETUP. The security code screen will be displayed. See Figure 4.53. You will be prompted to enter the security code.

Press **ESC** to stop and return to the MAIN PROGRAM SCREEN. Press **BKSP** to backspace or press **CLR** to delete the entry and start over. Press **ENTER** when finished.

After the correct security code has been entered, the first SYSTEM SETUP SCREEN will be displayed. See Figure 4.54.

Use ↓ and ↑ on the keypad to scroll up and down. Press ↓ when the arrow symbol (>) is next to Security Code, and the second SYSTEM SETUP SCREEN will be displayed. See Figure 4.55.

Press **ENTER** when the arrow symbol (>) is next to SPM Range. The SPM RANGE SCREEN will be displayed. See Figure 4.56.

Use ↓ and ↑ on the keypad to reach the appropriate SPM range. Press **ENTER** to finish.

Press **ESC** when finished to return to the MAIN PROGRAM SCREEN.

HOW TO PROGRAM THE LIGHT CURTAIN INPUT

Select the **ON** position of the program off/on selector switch. One of the MAIN PROGRAM SCREENS will be displayed.

On the MAIN PROGRAM SCREEN, use ↓ and ↑ on the keypad to scroll through the program options. Press **ENTER** when the pound symbol (#) is next to SYSTEM SETUP. The security code screen will be displayed. See Figure 4.53. You will be prompted to enter the security code.

Press **ESC** to stop and return to the MAIN PROGRAM SCREEN. Press **BKSP** to backspace or press **CLR** to delete the entry and start over. Press **ENTER** when finished.

After the correct security code has been entered, the first SYSTEM SETUP SCREEN will be displayed. See Figure 4.54.

Use ↓ and ↑ on the keypad to scroll up and down. Press ↓ when the arrow symbol (>) is next to Security Code, and the second SYSTEM SETUP SCREEN will be displayed. See Figure 4.55.

Press **ENTER** when the arrow symbol (>) is next to Light Curtain Input. The LIGHT CURTAIN INPUT SCREEN will be displayed. See Figure 4.57.

Use ↓ and ↑ on the keypad to select the appropriate light curtain input contact arrangement. Press **ENTER** to finish.

Press **ESC** when finished to return to the MAIN PROGRAM SCREEN.

Figure 4.53
Security Code Screen

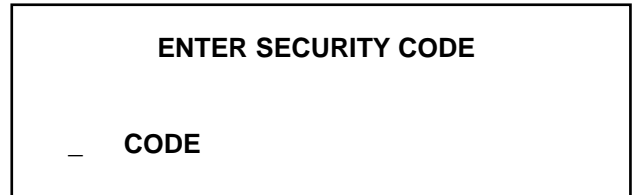

Figure 4.54
First System Setup Screen

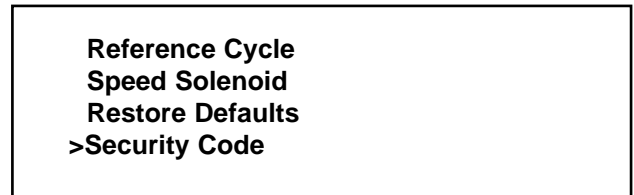

Figure 4.55
Second System Setup Screen

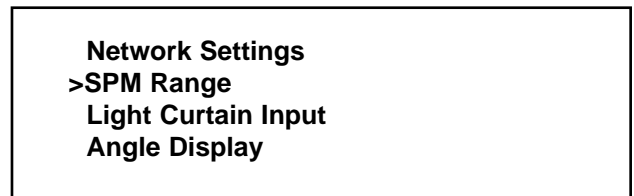

Figure 4.56
SPM Range Screen

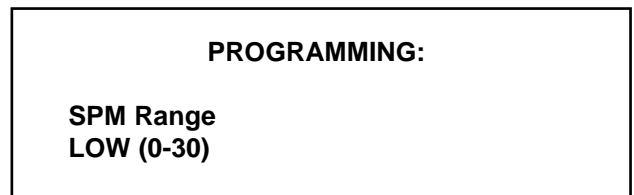
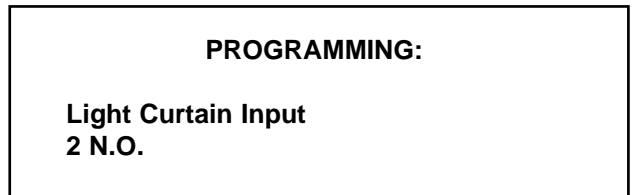

Figure 4.57
Light Curtain Input Screen



(Continued on next page.)

SECTION 4—PROGRAMMING

SSC1500 Part-Revolution Solid-State Control

HOW TO TURN ON OR OFF THE ANGLE DISPLAY

Select the **ON** position of the program off/on selector switch. One of the MAIN PROGRAM SCREENS will be displayed.

On the MAIN PROGRAM SCREEN, use ↓ and ↑ on the keypad to scroll through the program options. Press **ENTER** when the pound symbol (#) is next to SYSTEM SETUP. The security code screen will be displayed. See Figure 4.58. You will be prompted to enter the security code.

Press **ESC** to stop and return to the MAIN PROGRAM SCREEN. Press **BKSP** to backspace or press **CLR** to delete the entry and start over. Press **ENTER** when finished.

After the correct security code has been entered, the first SYSTEM SETUP SCREEN will be displayed. See Figure 4.59.

Use ↓ and ↑ on the keypad to scroll up and down. Press ↓ when the arrow symbol (>) is next to Security Code, and the second SYSTEM SETUP SCREEN will be displayed. See Figure 4.60.

Press **ENTER** when the arrow symbol (>) is next to Angle Display. The ANGLE DISPLAY SCREEN will be displayed. See Figure 4.62.

Use ↓ and ↑ on the keypad to toggle between ON and OFF. Press **ENTER** to finish.

Press **ESC** when finished to return to the MAIN PROGRAM SCREEN.

HOW TO TURN ON OR OFF SPANISH DISPLAY TEXT

Select the **ON** position of the program off/on selector switch. One of the MAIN PROGRAM SCREENS will be displayed.

On the MAIN PROGRAM SCREEN, use ↓ and ↑ on the keypad to scroll through the program options. Press **ENTER** when the pound symbol (#) is next to SYSTEM SETUP. The security code screen will be displayed. See Figure 4.58. You will be prompted to enter the security code.

Press **ESC** to stop and return to the MAIN PROGRAM SCREEN. Press **BKSP** to backspace or press **CLR** to delete the entry and start over. Press **ENTER** when finished.

After the correct security code has been entered, the first SYSTEM SETUP SCREEN will be displayed. See Figure 4.59.

Use ↓ and ↑ on the keypad to scroll up and down. Press ↓ when the arrow symbol (>) is next to Security Code, and the second SYSTEM SETUP SCREEN will be displayed. See Figure 4.60. Press ↓ when the arrow symbol (>) is next to Angle Display, and the third SYSTEM SETUP SCREEN will be displayed. See Figure 4.61.

Press **ENTER** when the arrow symbol (>) is next to Spanish. The SPANISH SCREEN will be displayed. See Figure 4.63.

Use ↓ and ↑ on the keypad to toggle between ON and OFF. Press **ENTER** to finish.

Press **ESC** when finished to return to the MAIN PROGRAM SCREEN.

Figure 4.58
Security Code Screen

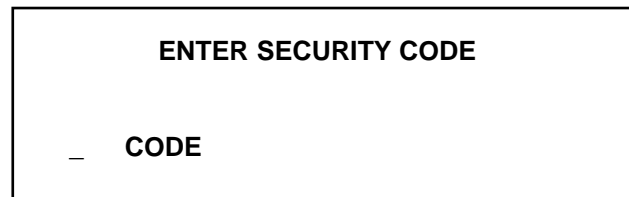

Figure 4.59
First System Setup Screen

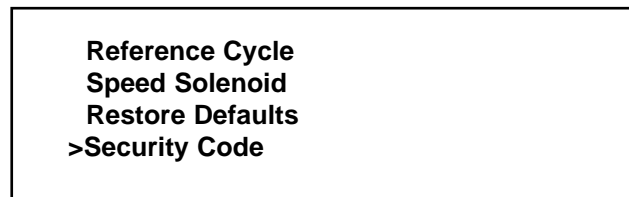

Figure 4.60
Second System Setup Screen

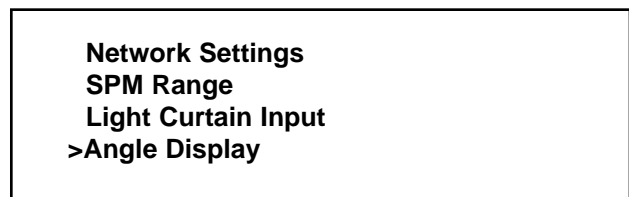

Figure 4.61
Third System Setup Screen



Figure 4.62
Angle Display Screen

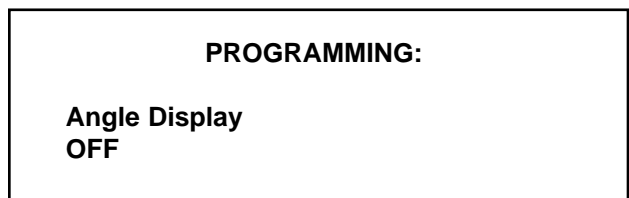
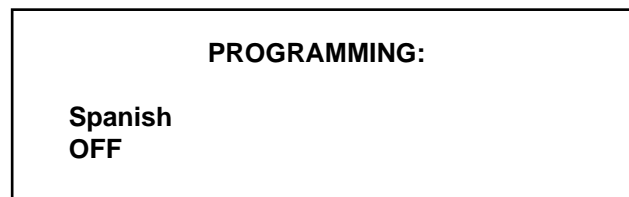

Figure 4.63
Spanish Screen



ANGLE SETTINGS

The SSC1500 press brake control has an angle settings screen that is used to program the single stroke top stop, sequence stop top stop, sequence stop, speed change on, speed change off, automatic up (holding), and light curtain mute angles.

SINGLE STROKE TOP-STOP ANGLE

The single stroke top-stop angle is the angle at which the control gives the signal to stop the machine at TDC (top dead center) while in the Single Stroke mode of operation. In most cases, you will need to adjust this setting, since the factory default of 330° may stop your machine beyond TDC. A good angle to start with is 270°. If the machine stops before TDC, a higher single stroke top-stop setting is required. Add the number of degrees the machine stopped short of TDC to the single stroke top-stop setting. If the machine stops beyond TDC, a lower single stroke top-stop setting is required. Subtract the number of degrees the machine went over TDC from the single stroke top-stop setting.

If your press brake has a variable-speed drive or a mechanical feature for changing speed, this setting may need to be adjusted if you change the speed.

SEQUENCE STOP TOP-STOP ANGLE

The sequence stop top-stop angle is the angle at which the control gives the signal to stop the machine at TDC while in the Sequence Stop mode of operation. In most cases, you will need to adjust this setting, since the factory default of 330° may stop your machine beyond TDC. A good angle to start with is 270°. If the machine stops before TDC, a higher sequence stop top-stop setting is required. If the machine stops beyond TDC, a lower sequence stop top-stop setting is required. Subtract the number of degrees the machine went over TDC from the sequence stop top-stop setting.

If your press brake has a variable-speed drive or a mechanical feature for changing speed, this setting may need to be adjusted if you change the speed.

SEQUENCE STOP ANGLE

The sequence stop angle is the angle at which the control gives the signal to stop on the downstroke while in the Sequence Stop mode of operation. This is usually programmed so that the slide stops at ¼" above the workpiece.

If your press brake has a variable-speed drive or a mechanical feature for changing speed, this setting may need to be adjusted if you change the speed.

Note: The sequence stop angle must be less than the light curtain mute angle.

SPEED CHANGE ON ANGLE

The speed change on angle is the angle at which the control gives the signal to switch from high to low speed when the speed selector switch is set to **HIGH/LOW**, while in any mode of operation. It is usually programmed so that the slide changes to low speed at ¼" above the workpiece.

Note: The speed change feature only applies to two-speed air-clutch press brakes. See pages 55 and 58 for information on programming the speed-change solenoid valve.

SPEED CHANGE OFF ANGLE

The speed change off angle is the angle at which the control gives the signal to switch from low speed back to high speed when the speed selector switch is set to **HIGH/LOW**, while in any mode of operation. It is usually programmed so that the slide changes back to high speed at the bottom of the stroke or slightly after.

Note: The speed change feature only applies to two-speed air-clutch press brakes. See pages 55 and 58 for information on programming the speed-change solenoid valve.

(Continued on next page.)

SECTION 4—PROGRAMMING

SSC1500 Part-Revolution Solid-State Control

AUTOMATIC UP (HOLDING) ANGLE

The automatic up (holding) angle is the angle beyond which the operator no longer needs to depress the palm buttons or foot switch to finish the cycle in progress. It applies when the machine is being run in the *Single Stroke* mode of operation, or during the second part of the stroke (after the sequence stop point is reached) in the *Sequence Stop* mode of operation. If the actuating means are released before the auto up angle is reached, the machine will stop. This angle can be changed, but should be programmed so the actuating means must be held depressed during the entire hazardous (die-closing) portion of the stroke.

LIGHT CURTAIN MUTE ANGLE

The light curtain mute angle is the angle beyond which the light curtain is no longer active. This means that once the light curtain mute angle is reached, the machine will not stop if the light curtain beams are interrupted. This angle can be changed, but should be programmed so the light curtain is muted only during the nonhazardous portion of the stroke.

Note: The light curtain mute angle cannot be less than or equal to the sequence stop angle.

HOW TO PROGRAM THE ANGLE SETTINGS

Select the **ON** position of the program off/on selector switch. One of the MAIN PROGRAM SCREENS will be displayed.

On the MAIN PROGRAM SCREEN, use ↓ and ↑ on the keypad to scroll through the program options. Press **ENTER** when the pound symbol (#) is next to ANGLE SETTINGS. The security code screen will be displayed. See Figure 4.64. You will be prompted to enter the security code.

Press **ESC** to stop and return to the MAIN PROGRAM SCREEN. Press **BKSP** to backspace or press **CLR** to delete the entry and start over. Press **ENTER** when finished.

After the correct security code has been entered, the first ANGLE SETTINGS SCREEN will be displayed. See Figure 4.65.

Use ↓ and ↑ on the keypad to scroll through the angle settings. If you press ↓ when the arrow symbol (>) is next to Speed Change On Angle, the second ANGLE SETTINGS SCREEN will be displayed. See Figure 4.66. Press **ENTER** when the arrow symbol (>) is next to the angle setting you want to program. A screen similar to the one shown in Figure 4.67 will be displayed.

Use the numeric keypad to enter a new angle. Press **ENTER** when finished.

Press **ESC** when finished to return to the MAIN PROGRAM SCREEN.

Figure 4.64
Security Code Screen

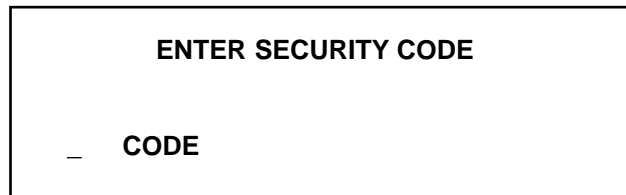

Figure 4.65
First Angle Settings Screen

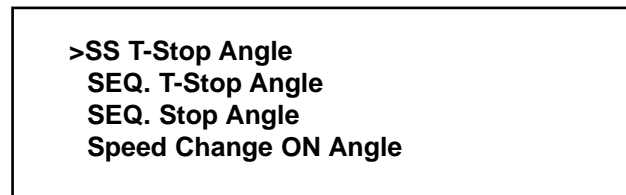

Figure 4.66
Second Angle Settings Screen

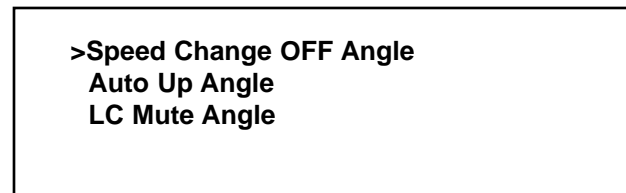
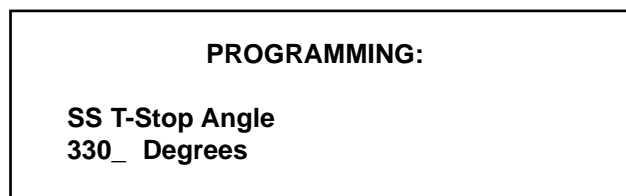

Figure 4.67
Example of a Programming Screen



TIMED SETTINGS

The SSC1500 press brake control has a timed settings screen that is used to program the anti-tie-down and timed inch settings.

ANTI-TIE-DOWN SETTING

The anti-tie-down setting is the amount of time within which all actuating means (palm buttons or foot switch[es]) must be concurrently depressed. Once one of the actuating means is depressed, the timer starts. If the set time is reached before the other actuating means is depressed, the control will not allow the machine to begin a stroke. The range of 100-7000 ms allows enough time for single or multiple operator stations to depress all actuating means. The typical setting for one operator is 250 ms, which is the factory default setting.

TIMED INCH SETTING

The timed inch setting is the amount of time for which the clutch will engage when in the *Inch* mode of operation. This prevents the operator from having to depress and release the palm buttons in rapid succession to get small increments of slide movement. The dual-solenoid valve is deenergized when the set time is reached, even though the palm buttons may be held activated.

If timed inch is not required, the programmed setting should be at 0 ms, which will disable this feature. When timed inch is disabled, the normal *Inch* mode of operation will be active. In the normal *Inch* mode, setup or maintenance personnel can hold the palm buttons, allowing continuous movement of the slide, or they can depress and release the palm buttons in rapid succession to allow only small increments of slide movement.

HOW TO PROGRAM THE TIMED SETTINGS

Select the **ON** position of the program off/on selector switch. One of the MAIN PROGRAM SCREENS will be displayed.

On the MAIN PROGRAM SCREEN, use ↓ and ↑ on the keypad to scroll through the program options. Press **ENTER** when the pound symbol (#) is next to TIMED SETTINGS. The security code screen will be displayed. See Figure 4.68. You will be prompted to enter the security code.

Press **ESC** to stop and return to the MAIN PROGRAM SCREEN. Press **BKSP** to backspace or press **CLR** to delete the entry and start over. Press **ENTER** when finished.

After the correct security code has been entered, the TIMED SETTINGS SCREEN will be displayed. See Figure 4.69.

Use ↓ and ↑ on the keypad to scroll through the timed settings. Press **ENTER** when the arrow symbol (>) is next to the timed setting you want to program. A screen similar to the one shown in Figure 4.70 will be displayed.

Use the numeric keypad to enter a new time. Press **ENTER** when finished.

Press **ESC** when finished to return to the MAIN PROGRAM SCREEN.

Figure 4.68
Security Code Screen

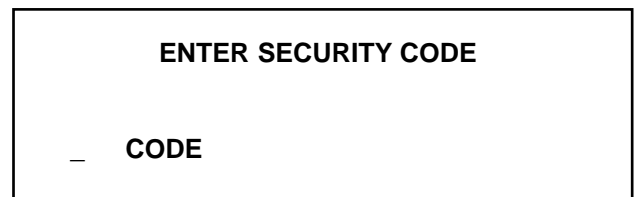

Figure 4.69
Timed Settings Screen

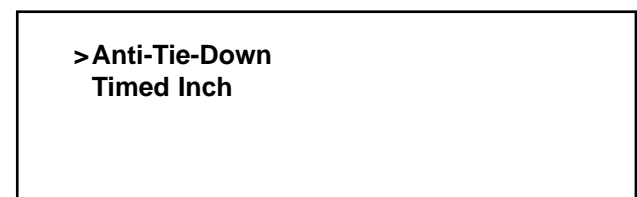
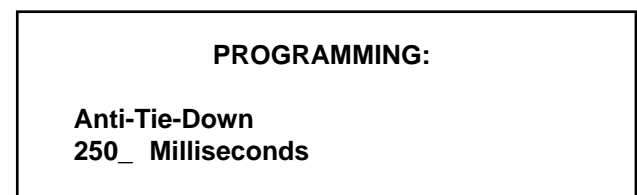

Figure 4.70
Example of a Programming Screen



SECTION 4—PROGRAMMING

SSC1500 Part-Revolution Solid-State Control

OPTIONAL MODES

The SSC-1500 press brake control has two (2) optional modes screens that are used to turn on or off *Top-Stop Inch* and *Inch With Fault*.

TOP-STOP INCH

Top-Stop Inch is a mode of operation that is similar to normal *Inch* (in which the slide travels as long as the operator(s) maintains actuation of the palm buttons). The difference is that if *Top-Stop Inch* is turned on, the slide will stop at the top of every cycle, even if the palm buttons are held depressed.

To use *Top-Stop Inch*, the mode selector must be set to **INCH**, the actuating means selector switch must be set to **HAND**, and this mode must be turned on in the optional modes programming screen.



The *Inch* mode of operation is used for die setup, tool setup, and maintenance only. It is not intended for use during production operations.

INCH WITH FAULT

Inch With Fault is the same mode of operation as normal *Inch*, but the control will allow the press brake to be cycled without general fault messages stopping it and being displayed. This allows the press brake to be set up easily without having to turn off the cyclic die protection inputs that would normally cause nuisance faults during setup.

To use *Inch With Fault*, the mode selector must be set to **INCH**, the actuating means selector switch must be set to **HAND**, and this mode must be turned on in the optional modes programming screen.



The *Inch* mode of operation is used for die setup, tool setup, and maintenance only. It is not intended for use during production operations.

HOW TO TURN ON OR OFF THE OPTIONAL MODES

Select the **ON** position of the program off/on selector switch. One of the MAIN PROGRAM SCREENS will be displayed.

On the MAIN PROGRAM SCREEN, use ↓ and ↑ on the keypad to scroll through the program options. Press **ENTER** when the pound symbol (#) is next to OPTIONAL MODES. The security code screen will be displayed. See Figure 4.71. You will be prompted to enter the security code.

Press **ESC** to stop and return to the MAIN PROGRAM SCREEN. Press **BKSP** to backspace or press **CLR** to delete the entry and start over. Press **ENTER** when finished.

After the correct security code has been entered, the OPTIONAL MODES SCREEN will be displayed. See Figure 4.72.

Use ↓ and ↑ on the keypad to scroll through the optional modes. Press **ENTER** when the arrow symbol (>) is next to the optional mode you want to turn on or off. A screen similar to the one shown in Figure 4.73 will be displayed.

Once in the programming screen of the optional mode you want to program, use ↓ and ↑ on the keypad to toggle the setting between ON and OFF. Press **ENTER** to finish.

Press **ESC** when finished to return to the MAIN PROGRAM SCREEN.

Figure 4.71
Security Code Screen

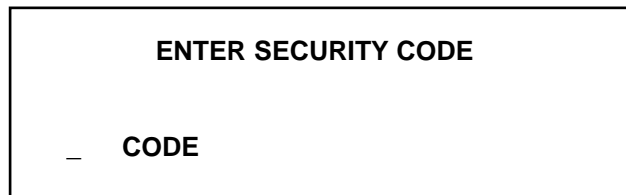

Figure 4.72
Optional Modes Screen

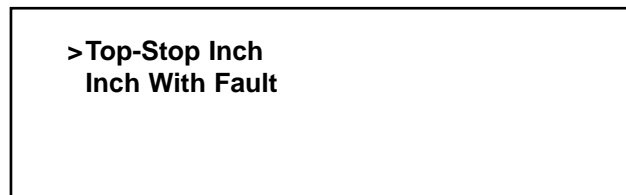
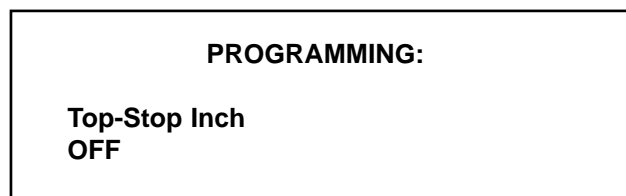

Figure 4.73
Example of a Programming Screen



PLS OUTPUT

The SSC1500 press brake control provides one (1) PLS (programmable limit switch) output relay which is fused for 4 A @ 115 V. This user-programmable output can be used to sequence events during the machine stroke.

The PLS output can be used for automatic operations such as lube mist, air blowoff, or feed initiation. The output has a programmable ON and OFF angle. The control turns the output ON when the resolver reaches the ON angle setting and leaves the output on until the OFF angle setting is reached. There is one ON setting and one OFF setting per revolution.

The output can also be programmed to turn off after a preset period of time in milliseconds. This timed off setting overrides any OFF angle setting, so the PLS output will turn off when the programmed time is reached, regardless of the OFF angle setting.

There is also a counter setting for a counted output. Auxiliary devices, such as lube or oil systems, can be interfaced so an output signal is provided when the counter setting is reached. For example, if an oil mist is required every three cycles, the counter setting is set to 3 strokes. When the counter reaches 3 strokes, the PLS output turns on, and the oil mist is given. The counter is then reset, and the cycle starts over.

HOW TO PROGRAM THE PLS OUTPUT

Select the **ON** position of the program off/on selector switch. One of the MAIN PROGRAM SCREENS will be displayed.

On the MAIN PROGRAM SCREEN, use ↓ and ↑ on the keypad to scroll through the program options. Press **ENTER** when the pound symbol (#) is next to PLS OUTPUT. The PLS PARAMETERS SCREEN will be displayed. See Figure 4.74.

Use ↓ and ↑ on the keypad to scroll through the programmable parameters. Press **ENTER** when the double arrow symbol (>>) is next to the parameter you want to program. A screen similar to the one shown in Figure 4.75 will be displayed. Once in the programming screen of the parameter you want to program, use the numeric keypad to enter a new setting. Press **ENTER** to finish.

Press **ESC** when finished to return to the MAIN PROGRAM SCREEN.

Figure 4.74
PLS Parameters Screen



Figure 4.75
Example of a Programming Screen

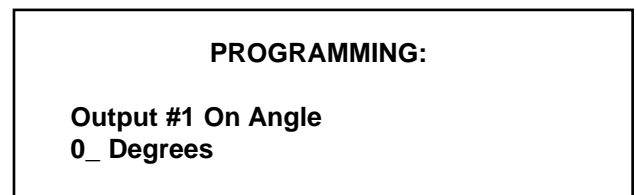

SECTION 4—PROGRAMMING

SSC1500 Part-Revolution Solid-State Control

AUXILIARY OUTPUT

The SSC1500 press brake control provides one (1) auxiliary output relay that has two contacts which are fused for 4 A @ 115 V. When this auxiliary output is set to be on, it can be programmed to change state whenever any or all of the following stop conditions occur: the batch counter setting is reached, a fault condition occurs, the machine stops, or the machine emergency stops. The output contacts can be programmed either N.O. (normally open) or N.C. (normally closed).

This auxiliary output can be tied in to a PLC (programmable logic controller) that's being used to control auxiliary equipment for the machine, such as a feeder, robot, or indexing table. This way, the auxiliary equipment will know when the machine has stopped, and can be programmed to stop as well. The output can also be used for something as simple as turning an indicator light on or off or sounding an audible alarm. Programming choices are either OFF or ON.

PROGRAMMABLE PARAMETERS FOR THE AUXILIARY OUTPUT

- 1. Aux Out Batch Count:** With this function turned on, the auxiliary output contacts will change state when the batch counter setting is reached. The programming choices are OFF or ON.
- 2. Aux Out Fault:** With this function turned on, the auxiliary output contacts will change state when a fault occurs. The programming choices are OFF or ON.
- 3. Aux Out Stop:** With this function turned on, the auxiliary output contacts will change state when the machine stops. The programming choices are OFF or ON.
- 4. Aux Out E-Stop:** With this function turned on, the auxiliary output contacts will change state when the machine is emergency stopped. The programming choices are OFF or ON.
- 5. Aux Out Logic:** This setting is used to change the logic that activates the output. The programming choices are N.O. (normally open) or N.C. (normally closed).

HOW TO PROGRAM THE AUXILIARY OUTPUT

Select the **ON** position of the program off/on selector switch. One of the MAIN PROGRAM SCREENS will be displayed.

On the MAIN PROGRAM SCREEN, use ↓ and ↑ on the keypad to scroll through the program options. Press **ENTER** when the pound symbol (#) is next to AUXILIARY OUTPUT. The security code screen will be displayed. See Figure 4.76. You will be prompted to enter the security code.

Press **ESC** to stop and return to the MAIN PROGRAM SCREEN. Press **BKSP** to backspace or press **CLR** to delete the entry and start over. Press **ENTER** when finished.

After the correct security code has been entered, the first PROGRAMMABLE PARAMETERS SCREEN will be displayed. See Figure 4.77.

Figure 4.76
Security Code Screen

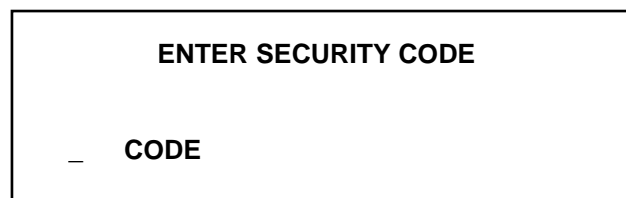
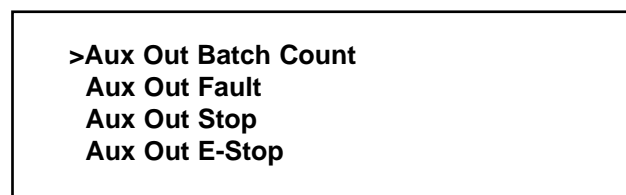

Figure 4.77
First Programmable Parameters Screen



(Continued on next page.)

HOW TO PROGRAM THE AUXILIARY OUTPUT (continued)

Use ↓ and ↑ on the keypad to scroll through the programmable parameters. If you press ↓ when the arrow symbol (>) is next to Aux Out E-Stop, the second PROGRAMMABLE PARAMETERS SCREEN will be displayed. See Figure 4.78. Press **ENTER** when the arrow symbol (>) is next to the parameter you want to program. A screen similar to the one shown in Figure 4.79 will be displayed.

Once you are in the programming screen of the parameter you want to program, use ↓ and ↑ on the keypad to reach the setting you desire for that parameter. Press **ENTER** to finish.

Press **ESC** when finished to return to the MAIN PROGRAM SCREEN.

Figure 4.78
Second Programmable Parameters Screen

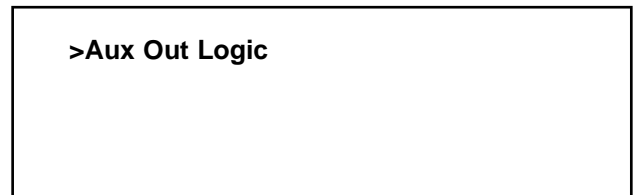
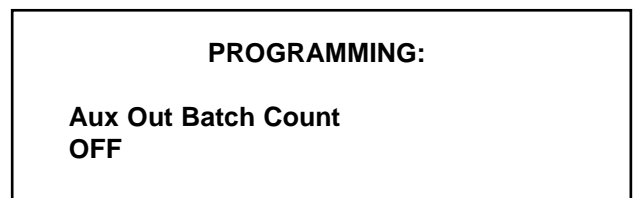

Figure 4.79
Example of Programming Screen



SECTION 4—PROGRAMMING

SSC1500 Part-Revolution Solid-State Control

QUICK REFERENCE TABLE—FACTORY SETTINGS AND VALID RANGES

Table 4.1

Program Setting	Valid Entry Range		Factory Default Setting		
User Inputs 1-3 and User Input 6	Logic:	Off, N.O., or N.C	Logic:	Off	
	Stop Type:	E-Stop or Top Stop	Stop Type:	E-Stop	
	Message:	See list of User Messages (p. 46)	Message:	Clutch/Brake Air Fault	
User Input 4	Logic:	Off, N.O., N.C., N.O.(PAIR), or N.C.(PAIR)	Logic:	Off	
	Stop Type:	E-Stop or Top Stop	Stop Type:	E-Stop	
	Message:	See list of User Messages (p. 46)	Message:	Clutch/Brake Air Fault	
User Input 5	Logic:	Off, N.O., or N.C.	Logic:	Off	
	Stop Type:	E-Stop or Top Stop	Stop Type:	E-Stop	
	Message:	See list of User Messages (p. 46)	Message:	Clutch/Brake Air Fault	
	Note: When paired together with User Input 4, you will not be able to make programming changes to this input until it is unpaired by changing the logic for User Input 4 to OFF, N.O., or N.C.				
User Inputs 7-8	Logic:	Off, N.O., or N.C.	Logic:	Off	
	Stop Type:	E-Stop or Top Stop	Stop Type:	E-Stop	
	Message:	See list of User Messages (p. 46)	Message:	Clutch/Brake Air Fault	
	Open Angle:	0°-359°	Open Angle:	0°	
	Close Angle:	0°-359°	Close Angle:	0°	
Brake Monitor	Warning Setpoint:	0-999 ms	Warning Setpoint:	50 ms	
	Fault Setpoint:	0-999 ms	Fault Setpoint:	50 ms	
	STM Angle:	20°-340°	STM Angle:	90°	
Counters	Batch & Stroke Preset:	0-9,999,999 strokes	Batch & Stroke Preset:	0 strokes	
System Setup	Security Code:	User-programmed up to a 4-digit #	Security Code:	0	
	Name:	User-programmed up to 17 alphanumeric characters	Name:	MYNAME	
	Network Settings:	Work Group:	User-programmed up to 17 alphanumeric characters	Work Group:	MYGROUP
		Address:	User-programmed from 0.0.0.0 to 255.255.255.255	Address:	127.0.0.1
		Mask:	User-programmed from 0.0.0.0 to 255.255.255.255	Mask:	255.255.255.0
		Mode:	Static or DHCP	Mode:	Static
	SPM Range:	Low (0-30), Med (31-50), or High (151+)	SPM Range:	Low (0-30)	
	Light Curtain Input:	2 N.O. or 1 N.O. & 1 N.C.	Light Curtain Input:	2 N.O.	
	Angle Display:	On or Off	Angle Display:	Off	
	Spanish:	On or Off	Spanish:	Off	
Angle Settings	Single Stroke Top Stop:	90°-359°	Single Stroke Top Stop:	330°	
	Sequence Stop Top Stop:	90°-359°	Sequence Stop Top Stop:	330°	
	Sequence Stop:	30°-170°	Sequence Stop:	120°	
	Speed Change On:	30°-270°	Speed Change On:	120°	
	Speed Change Off:	90°-359°	Speed Change Off:	190°	
	Automatic Up:	90°-345°	Automatic Up:	180°	
	Light Curtain Mute:	45°-345°	Light Curtain Mute:	170°	

(Continued on next page.)

SECTION 4—PROGRAMMING

SSC1500 Part-Revolution Solid-State Control

QUICK REFERENCE TABLE - FACTORY SETTINGS AND VALID RANGES (Continued) Table 4.1 (continued)

Program Setting	Valid Entry Range		Factory Default Setting	
Timed Settings	Anti-Tie-Down:	100-7000 ms	Anti-Tie-Down:	250 ms
	Timed Inch:	0-999 ms	Timed Inch:	0 ms (Off)
Optional Modes	Top-Stop Inch:	On or Off	Top-Stop Inch:	Off
	Inch With Fault:	On or Off	Inch With Fault:	Off
PLS Output	On Angle:	0°-359°	On Angle:	0°
	Off Angle:	0°-359°	Off Angle:	0°
	Counter:	0-999 strokes	Counter:	0 strokes
	Timed Off:	0-999 ms	Timed Off:	0 ms
Auxiliary Output	Aux. Out. Batch Count:	Off	Aux. Out. Batch Count:	Off
	Aux. Out. Fault:	Off	Aux. Out. Fault:	Off
	Aux. Out. Stop:	Off	Aux. Out. Stop:	Off
	Aux. Out. E-Stop:	Off	Aux. Out. E-Stop:	Off
	Aux. Out. Logic:	N.O. (Normally Open) or N.C. (Normally Closed)	Aux. Out. Logic:	N.O. (Normally Open)

SECTION 5—FATAL AND GENERAL FAULT MESSAGES

SSC1500 Part-Revolution Solid-State Control

Fatal Fault Messages

Fatal fault messages CANNOT be cleared. An emergency stop or a power shut off is required for the control to recover. The problem should be addressed before running the machine again.

For all fatal fault messages (except the two diagnostic faults), the first two lines of the screen will display this followed by the fault message:

<SYSTEM FAULT>
<E-STOP TO CLEAR>

(FAULT MESSAGE IS DISPLAYED HERE)

Table 5.1

Message	Description/Solution
CPU #2 ACKN FLT	A signal that was being monitored by CPU #2 did not behave as expected. Turn the module power switch off for 5 to 10 seconds. Turn it back on and proceed as normal. If the message persists, the module may need to be replaced. Possible circuit failure; consult the factory.
CPU #2 SSRON FLT	The SSRs (solid-state relays) did not turn on while being monitored by CPU #2. Turn the module power switch off for 5 to 10 seconds. Turn it back on and proceed as normal. If the message persists, the module may need to be replaced. Possible circuit failure; consult the factory.
DIAGNOSTIC FAULT #1 KILL POWER TO CLEAR	A diagnostic test of a monitoring circuit failed during power-up. Turn the module power switch off for 5 to 10 seconds. Turn it back on and proceed as normal. If the message persists, the module may need to be replaced. Possible circuit failure; consult the factory.
DIAGNOSTIC FAULT #2 KILL POWER TO CLEAR	A diagnostic test of a redundant safety circuit failed. Turn the module power switch off for 5 to 10 seconds. Turn it back on and proceed as normal. If the message persists, the module may need to be replaced. Possible circuit failure; consult the factory.
INVALID PAIR SIGNALS	User Inputs 4 and 5 are paired together, but they did not change state within 500 milliseconds of each other. Check the equipment tied in to Inputs 4 and 5 for possible failure.
MOTION DROPPED	The machine cycle lost motion once it was sensed at the start of the cycle. Check that the machine is running at 4 SPM or greater. If this message persists, rerun the reference cycle from TDC and note the reference time reported. Possible circuit failure; consult the factory.
MOTION, NO RUN	The control detected motion prior to starting a machine cycle. Check for correct wiring to the resolver connection on the SSC1500 control module. Verify the chain is on the sprocket for the resolver and is tight. Check that the SPM display is 000 when the crankshaft is at rest, or prior to starting a machine cycle. Verify the resolver cable is not run near high-voltage lines (motor leads). Possible circuit failure; consult the factory.
MOTION REFERENCE FLT	The machine cycle did not produce motion within the given reference time allotted. Check that the machine is running at full speed and the air pressure hasn't dropped. If this message persists, rerun a reference cycle from TDC and note the reference time reported. Possible circuit failure; consult the factory.

(Continued on next page.)

SECTION 5—FATAL AND GENERAL FAULT MESSAGES

SSC1500 Part-Revolution Solid-State Control

Fatal Fault Messages (continued)

Table 5.1 (continued)

Message	Description/Solution
RESOLVER NOT WORKING	Velocity is present but the resolver is not moving. Check for correct wiring to the resolver connection on the SSC1500 control module. Verify that the resolver cable is not run near high-voltage lines (motor leads). Possible circuit failure; consult the factory.
RESOLVER READ ERROR	Three successive reads of the resolver position failed to produce the same value. Possible circuit failure; consult the factory.
RESOLVER/SYNC FLT 1	The sync switch in the resolver housing came on outside its window that was set during the reference cycle. Check that nothing else is turning on the sync switch input. Verify that the resolver cable is not run near high-voltage lines (motor leads). Check the resolver chain or coupling for tightness and make sure there is no backlash or slop. Check the resolver cable and ensure that the sync switch LED on the SSC1500 control module is functioning and is not coming on during the bottom of the stroke. If it is coming on at the bottom of the stroke, remove the chain or coupling from the resolver shaft and rotate the resolver shaft so the sync switch does not come on at the bottom of the stroke. Run a reference cycle again. Possible circuit failure; consult the factory.
RESOLVER/SYNC FLT 2	The sync switch in the resolver housing never came on during the machine cycle. Check that no wires have come loose inside the resolver housing or where the resolver cable connects to the SSC1500 control module. Make sure the sync switch LED on the SSC1500 control module is functioning. Make sure the chain has not fallen off during the machine cycle. Possible circuit failure; consult the factory.
SSR1 or K1 OFF FLT	SSR1 (solid-state relay 1) and/or K1 safety relay did not shut off and voltage was detected via the redundant feedback circuit. Turn the module power switch off for 5 to 10 seconds. Turn it back on and proceed as normal. If the message persists, the module may need to be replaced. Possible circuit failure; consult the factory.
SSR1 or K1 ON FLT	SSR1 (solid-state relay 1) and/or K1 safety relay did not turn on and voltage was not detected via the redundant feedback circuit. Turn the module power switch off for 5 to 10 seconds. Turn it back on and proceed as normal. If the message persists, the module may need to be replaced. Possible circuit failure; consult the factory.
SSR1 or SSR2 OFF FLT	One or both SSRs (solid-state relays) did not shut off and voltage was detected via the redundant feedback circuit. Turn the module power switch off for 5 to 10 seconds. Turn it back on and proceed as normal. If the message persists, the module may need to be replaced. Possible circuit failure; consult the factory.
SSR2 OFF FLT	SSR2 (solid-state relay 2) did not shut off and voltage was detected via the redundant feedback circuit. Turn the module power switch off for 5 to 10 seconds. Turn it back on and proceed as normal. If the message persists, the module may need to be replaced. Possible circuit failure; consult the factory.
SSR2 ON FLT	SSR2 (solid-state relay 2) did not turn on and voltage was not detected via the redundant feedback circuit. Turn the module power switch off for 5 to 10 seconds. Turn it back on and proceed as normal. If the message persists, the module may need to be replaced. Possible circuit failure; consult the factory.

SECTION 5—FATAL AND GENERAL FAULT MESSAGES

SSC1500 Part-Revolution Solid-State Control

General Fault Messages

Most general fault messages can be cleared by pressing **ENTER** on the keypad.

Table 5.2

Message	Description/Solution
BATCH COUNT EXPIRED	The batch count has reached the programmed preset value and the press is now stopped. To clear the message and reset the counter, press ENTER on the keypad. See page 53 for information on programming the batch preset.
BATTERY BACK-UP MEMORY FAILED! DEFAULTS WERE SET. PRESS ESC TO EXIT	The battery back-up memory failed. Clear the fault. Turn off the power switch for 5 to 10 seconds. Turn it back on and proceed as normal. If message persists, the battery may need to be replaced on the module. Possible circuit failure; consult the factory.
BRAKE FAULT	The stopping time has exceeded the programmed limit for the brake fault setting. When this message is displayed, acknowledge the message by pressing ENTER and it will clear. No machine action can be initiated during this time. Once it clears, continue with normal operation. If faults persist, consult your supervisor, as the brake may need inspection or adjustment to improve the stop time. See pages 50-52 for a detailed description of the brake monitor.
BRAKE WARNING	The stopping time has exceeded the programmed limit for the brake warning setting. This message is displayed for 5 seconds and then clears automatically. No machine action can be initiated during this time. Wait for it to clear and continue with normal operation. If warnings persist, consult your supervisor, as the brake may need inspection or adjustment to improve the stop time. See pages 50-52 for a detailed description of the brake monitor.
DO REFERENCE CYCLE	A valid reference cycle has not been done. Perform a reference cycle. See page 57 for detailed instructions.
*****ERROR!***** MUTE ANG <= TO THE SEQ STOP ANGLE. GO BACK TO PROGRAM.	The light curtain mute angle has been programmed at less than or equal to the sequence stop angle. The light curtain cannot be muted until after the sequence stop angle. See pages 65-66 for information on programming the angle settings.
HAND ONLY	The mode selector switch is in INCH and the actuating means selector is in FOOT . <i>Inch</i> mode cannot be actuated with the foot switch. Change either selector switch to the proper setting and continue.
HAND OR FOOT ONLY	The mode selector switch is in SINGLE and the actuating means selector is in HAND/FOOT . Hand/foot can only be use in the <i>Sequence Stop</i> mode of operation.
LC BROKEN	An attempt was made to perform an STM test while the light curtain was obstructed or was not in the clear (green) state. Make sure there is nothing obstructing the light curtain. If the problem persists, refer to the light curtain installation manual for troubleshooting.
LC CYCLE FAULT	The light curtain cycle check wired to the MTS input on the light curtain failed to cycle on the upstroke. Check the LED for the K4 relay on the SSC1500 control module, and fuses F5 and F6 for the LC cycle output contact.
MOTOR NOT FORWARD	Verify that the main motor is running in the forward direction. Verify that Input P8-16 is on.
NO INTERLOCKS	An attempt was made to initiate a cycle in either <i>Foot Single Stroke</i> or <i>Foot Sequence Stop</i> and there was no interlock; i.e., light curtain(s) or safeguard interlock(s).
MACHINE NOT AT TOP	An attempt to initiate a single stroke has been made when the resolver/crankshaft angle is between the top stop angle and 345°. Change the mode selector to INCH and inch the slide up past 345°. Change the selector to SINGLE and retry.

(Continued on next page.)

SECTION 5—FATAL AND GENERAL FAULT MESSAGES

SSC1500 Part-Revolution Solid-State Control

General Fault Messages (continued)

Table 5.2 (continued)

Message	Description/Solution
PAIRED WITH INPUT #4	An attempt was made to program User Input 5, but it is paired with User Input 4. This message is displayed for 2 seconds and then clears automatically. To unpair the inputs, the logic for Input 4 must be changed to N.O. (normally open), N.C. (normally closed), or OFF (disabled). See pages 46–49 for information on programming the user inputs.
PROG ON	An attempt was made to switch to program on while the machine was running.
STM TEST FAILED	The palm buttons were released early during the STM test. Refer to pages 50-51 and retry.
REFERENCE FAILED! NO MOTION WITHIN 1.5 SECONDS. PRESS ESC TO EXIT	The resolver did not detect motion within 1.5 seconds during the reference cycle. Check that the resolver is wired correctly, and run the reference cycle again. Possible circuit failure; consult the factory.
REFERENCE FAILED! PALM BUTTONS WERE RELEASED EARLY. PRESS ESC TO EXIT	The palm buttons were released early during the reference cycle. Rerun the reference cycle and hold the palm buttons until the machine stops on its own. Verify resolver direction. Switch the mode selector to INCH and verify that SPM is displayed when running.
REFERENCE FAILED! SYNC SWITCH WAS NOT DETECTED. PRESS ESC TO EXIT	The sync switch in the resolver housing did not come on during the reference cycle. The sync switch can only come on between 30° and 330°. The ideal location is around 90° for most press brakes. Check the wiring for the resolver and check the LED on the control module for the sync switch input to ensure it is functioning. Ensure the machine is at TDC when doing the reference cycle. If needed, remove the chain or coupling from the resolver drive and rotate until the sync switch signal is not over top, and falls within 30° and 330°. Run a reference cycle again. Possible circuit failure; consult the factory.
REFERENCE FAILED! SYNC SWITCH CANNOT BE ON WHEN STARTING. PRESS ESC TO EXIT	Reposition the resolver so the sync switch in the resolver housing is not on at the top of the stroke. Make sure the resolver shaft keyway is perpendicular to the base at TDC.
STROKE COUNT EXPIRED	The stroke count has reached the programmed preset value and the press is now stopped. To clear the message and reset the counter, press ENTER on the keypad. See pages 53-54 for information on programming the stroke preset.
SWITCH TO HAND	When performing a reference cycle or STM test, hand is the only means of actuation. Switch the actuating means selector to HAND and continue.

SECTION 6—OPERATING CONSIDERATIONS

SSC1500 Part-Revolution Solid-State Control

SSC1500 Operation Checklist

1. Is all wiring to the machine, the solid-state control module (black box), and keypad/display correct when verified with the drawings sent with the solid-state control?.....Y or N
2. Does the connection between the resolver/pulser cable and the P5 connector exist, as referenced in the wiring diagram? (See page 26 or Sheet No. 2 of the schematics.).....Y or N
3. Does the resolver/pulser cable have any splices? (Answer should be NO.).....Y or N
4. When powering up the solid-state control module, do the four (green) LEDs (Power Status and CPU) on the front of the black control module turn on?.....Y or N
5. Is the WAKE UP SCREEN displayed with the message: “**SAFEGUARDS IN PLACE?**” when the main power disconnect switch is turned on?.....Y or N
6. With no slide motion, check the SPM reading on the RUN SCREEN. Visually verify that SPM is displaying 000 with no flickering of the numbers.....Y or N (If numbers are flickering, please consult the factory.)
7. Was the **POWER-UP PROCEDURE** performed at TDC (top dead center) of crankshaft rotation? (See page 44 of this Installation Manual).....Y or N
Note: The shaft extension of the resolver must have the keyway up and perpendicular to the base of the assembly when setting the resolver.)
8. The resolver/pulser assembly was shipped with the print shown for clockwise (CW) rotation (when looking at the shaft extension where the sprocket is attached). If this assembly is mounted to operate in a counterclockwise (CCW) rotation, the resolver wiring must be reset for counterclockwise rotation. Refer to page 26 or Sheet No. 2 of the schematics shipped with the control box. Does the above checkout?.....Y or N
9. In normal run modes, such as *Single* or *Sequence Stop*, does the machine make cycles without any faults appearing on the display?.....Y or N

Electrical Troubleshooting

All troubleshooting, as well as installation, must be performed by qualified and properly trained personnel. Also, when a defective component is found, do not operate the machine until that component has been replaced with an exact replacement part.

This procedure is written as a general guide for troubleshooting most part-revolution control systems. In all cases, please refer to the individual control wiring schematic for particular test points and terminal numbers. Be sure to follow the schematic and select the proper modes of operation when troubleshooting.

If a defective component (contact) is found, always verify with an ohm meter. Lock the disconnect switch in the off position, isolate the component or contact from other wiring and check its integrity with an ohm meter. At the same time, manually operate the device (in the case of a contact) to check its function.

The following should be checked if your machine is not functioning properly at this time:

Check the exhaust port and muffler on the dual-solenoid valve. The exhaust port and exhaust muffler must be clean and unobstructed so an unrestricted flow of exhaust air from the air cylinder or clutch/brake is obtained.

(Continued on next page.)

TROUBLESHOOTING OUTLINE

Use the control drawing schematics in conjunction with the following troubleshooting outline:

NO VOLTAGE—POSSIBLE CAUSES:

1. Check the line voltage on the transformer primary with a volt meter.
2. Check for correct transformer primary connections (wiring) and the secondary for 120 V AC using a volt meter.
3. A primary or secondary fuse may be blown—replace the fuse with the proper size, type, and amperage in accordance with the control drawing. Using an ohm meter, locate the reason for the blown fuse before reapplying power.

MOTOR DOES NOT START—POSSIBLE CAUSES:

1. Open electrical interlocks. The circuit can be arranged to accommodate machine protective electrical interlocks, overload interlocks, and safety block interlocks. These interlocks are strategically located to prevent machine operation when open. Please refer to the schematic for the location of the various interlocks.

2. Motor starter does not energize.

Motor starter operating coil may not be 120 V AC.

Motor overload may have tripped out; this may have been caused because no overload is present or because of an improperly rated overload.

Motor start/stop push buttons may be improperly wired or defective.

Motor starter contact may be defective.

- The motor should start if the above checks OK. If the motor still fails to run when the start button is released, check the motor starter holding contact for proper wiring and function.

MACHINE WILL NOT STROKE—POSSIBLE CAUSES:

Clutch will not engage and the brake will not release

- Air supply may be off.
- Air pressure may be insufficient.

Dual-solenoid air valve will not energize

- Check for proper installation and wiring.
- Solenoid coils may be open.

LIGHT CURTAIN (IF FURNISHED) IS NOT FUNCTIONING—POSSIBLE CAUSE:

Fuse F5 or F6 may be faulty (if light curtain MTS contact is wired in to P7)

PLS NOT FUNCTIONING—POSSIBLE CAUSE:

Fuse F3 or F4 may be faulty

SECTION 7—MAINTENANCE AND INSPECTION

SSC1500 Part-Revolution Solid-State Control

Part-Revolution-Clutch Press Brake

A part-revolution-clutch mechanical power press brake consists of engaging parts, springs, electrical components, air components and other mechanical equipment. Because of this inherent design, machine parts will ultimately wear, get out of adjustment or break which could cause a malfunction and/or mechanical failure. The control system furnished can never cure nor overcome a misadjusted, worn, broken or malfunctioning part or mechanical failure. Be sure to inspect all parts for adjustment, excessive wear, looseness or breakage. **Do not operate your machines until all parts are adjusted, repaired, replaced, and each entire machine is working properly.**

Visual inspections and examinations of the machine and its components must be made at least once per shift by qualified personnel.

Machines must always be inspected and tested on a weekly basis to determine the condition of the clutch/brake mechanism and antirepeat feature. Necessary maintenance and repair must be done before each machine is operated again, and the employer must maintain records of both the inspections and the maintenance work performed.



After any maintenance, always operate the machine numerous times in all modes of operation before allowing the operator to start production. Always make sure point-of-operation safeguarding is in place, adjusted and operating properly for the job and for the operator.

ANSI Requirements for Inspections

ANSI B11.3—INSPECTION AND MAINTENANCE RECORDS

It is the user's responsibility to set up and maintain periodic and regular inspections of the press brake to make sure all of its parts, components, auxiliary equipment, and safeguards are adjusted and in safe operating condition. Records of inspections and maintenance on each press brake shall be kept.

ANSI Requirements for Operator Training

ANSI B11.3—TRAINING

It is the user's responsibility to set up a training program to make sure operators, die setters, inspectors, maintenance personnel, and supervisors are qualified for the job they are performing, and that they are properly trained in safe working procedures. These individuals shall also be properly trained in the safe working procedures for lockout/tagout of hazardous energy sources according to 29 CFR 1910.147 & 1910.333.

Electrical Controls

Before inspecting or maintaining electrical controls, be sure to switch the main power disconnect to the off position and lockout all energy. Perform a periodic inspection of the control box and electrical machine components for loose or broken wires. Be sure relays and switches are examined for burned or worn contacts. Look for loose or broken conduit and cable fittings. The control box and other components must be kept closed, covered, and locked to keep unauthorized personnel out. Keys must be removed from all selector switches and door locks to prevent tampering and prevent exposure to the dirt, chips, and oil present in most shops.

Air System

1. Be sure to turn the air pressure off, bleed air from the system or component, and lockout before maintaining any air equipment.
2. Inspection of the entire air system is dependent on the frequency of machine operation and the cleanliness of the plant air lines. Both free moisture and solids should be removed automatically by the air filter. Be sure to drain the filter bowl whenever the water level in the sump reaches the lower baffle. To remove the filter element for cleaning, shut air line down and exhaust pressure. See Filter-Regulator-Lubricator Installation Manual No. KSL208 and page 28 of this manual.
3. Be sure to check the lubricator for proper oil level and oil delivery adjustment. See Installation Manual No. KSL208.
4. The monitored dual-solenoid air valve that operates the air cylinder (or operates the clutch and releases the brake) must be protected from foreign material getting into the valve. The valve relies on the performance of the air filter. The valve's exhaust muffler must be removed regularly and cleaned so dumping of air is unrestricted. Refer to Installation Manual No. KSL036 and page 28 of this manual.



The maintenance and inspection sections in this manual cannot be all-inclusive. Always refer to the original equipment manufacturer's maintenance manuals or the machine owner's manual. If you do not have an owner's manual, contact the machine manufacturer.

Care of the Keypad/Display

To clean the keypad/display, use a clean soft cloth with soap and warm water, but do not saturate. Do not use oily rags, solvents, or ammonia-based glass cleaner.

SECTION 8—REPLACEMENT PROCEDURES

SSC1500 Part-Revolution Solid-State Control

Replacing the Core Module

Photo 8.1



Photo 8.2



Photo 8.3



Photo 8.4

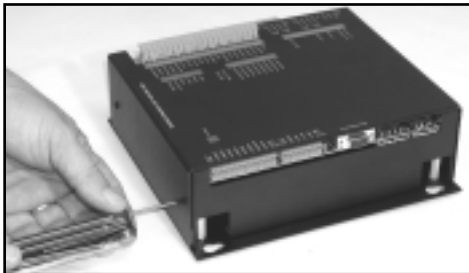

Photo 8.5

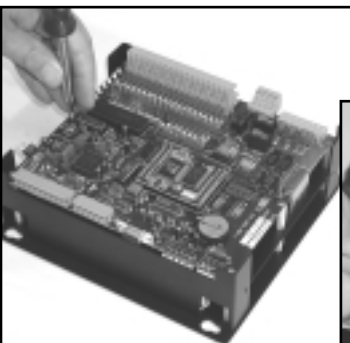
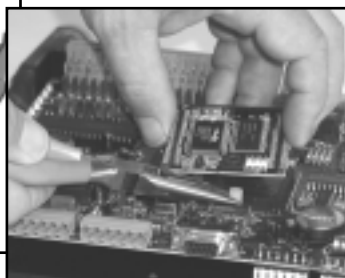

Photo 8.6



All power to the machine must be off before replacing the control module or any other parts.

1. Locate the control module inside the control box.
2. Remove all terminal strips from the left and right sides of the circuit board. Unplug the main power cord from the left side of the module. See Photo 8.1.
3. Loosen the four Allen-head bolts (Photo 8.2) and lift up on the control module. Pull the unit straight out. See Photo 8.3.
4. Remove the four small screws from the cover of the control module (Photo 8.4) and lift the cover straight up.
5. Remove the eight small screws from the circuit board (Photo 8.5) and lift the circuit board straight up.
6. Locate the core module in the center of the circuit board. Remove the small screw and lift the core module out by gently wiggling it back and forth. Keep track of the nylon spacer.
7. Insert the new core module onto the circuit board keeping the nylon spacer in place. See Photo 8.6. Tighten the screw.
8. Place the circuit board back on the control module and secure it with the eight screws.
9. Place the cover back on the control module and secure it with the four screws.
10. Put the control module back in place, tighten the Allen-head bolts, plug in the main power cord, and insert all terminal strips.

SECTION 8—REPLACEMENT PROCEDURES

SSC1500 Part-Revolution Solid-State Control

Replacing Fuses F1-F6

Photo 8.7

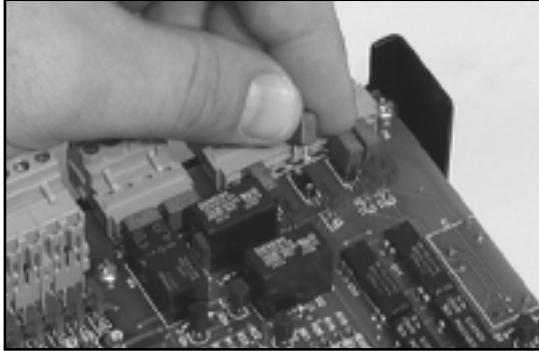

All power to the machine must be off before replacing the battery or any other parts.

1. Remove the control module from the control box (steps 1-3 on page 82).
2. Remove the top cover plate from the SSC1500 control module by removing the four small screws.
3. Locate fuses F1-F6. Grasp the faulty fuse and pull straight up. (Fuses are Wickman 4-A/250-V slow-blow Part No. 3961400044.)
4. Insert the new fuse by lining up the pins with the holes on the circuit board. See Photo 8.7.
5. Replace the cover plate back on the control module and secure it with the four screws.
6. Put the control module back in place, tighten the Allen-head bolts, plug in the main power cord, and insert all terminal strips.

Replacing the Main Power Fuses

Photo 8.8

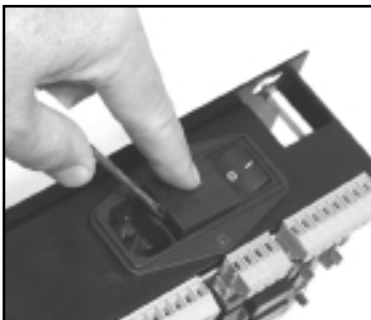

All power to the machine must be off before replacing the battery or any other parts.

1. Remove the control module from the control box (steps 1-3 on page 82).
2. Locate the main power on/off switch on the left side of the control module. Insert a small screwdriver in the slot just above the three prongs and lift up (see Photo 8.8). The fuse holder should pop out.
3. Locate and unclip the faulty fuse(s). Insert a new fuse. See Photo 8.9. Snap the fuse holder back into the main power on/off switch. (Fuses are Bussman 4-A/250-V slow-blow Part No. 6DC-4A.)
4. Put the control module back in place, tighten the Allen-head bolts, plug in the main power cord, and insert all terminal strips.

Photo 8.9



SECTION 8—REPLACEMENT PROCEDURES

SSC1500 Part-Revolution Solid-State Control

Replacing the Battery

Photo 8.10

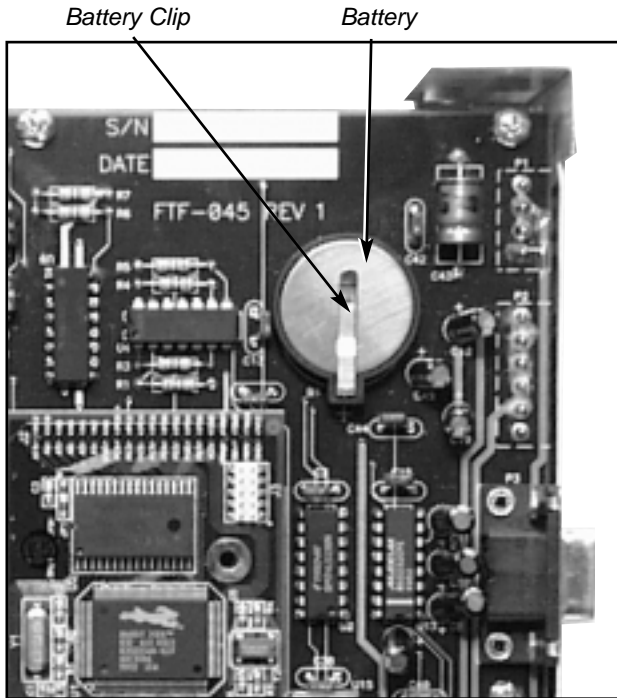

All power to the machine must be off before replacing the battery or any other parts.

1. Remove the control module from the control box (steps 1-3 on page 82).
2. Remove the top cover plate from the SSC1500 control module by removing the four screws.
3. Locate the battery on the control module. See Photo 8.10. Carefully lift the battery clip up and remove the battery.
4. Insert the new battery.
5. Put the cover plate back onto the control module and secure it with the four screws.
6. Put the control module back in place, tighten the Allen-head bolts, plug in the main power cord, and insert all terminal strips.

Note: When the battery fails or has been removed, all programmable information will return to factory defaults (see pages 72-73). All user inputs will need to be reprogrammed.

SECTION 9—METHODS OF SAFEGUARDING

SSC1500 Part-Revolution Solid-State Control

Please refer to the ANSI B11.3 standard for the requirements for point-of-operation safeguarding on press brakes. When updating a press brake, the most important decision is the selection of the proper guard or device. The following are methods of safeguarding part-revolution press brakes.

LIGHT CURTAIN PRESENCE-SENSING DEVICES ON PRESS BRAKES

ANSI B11.3

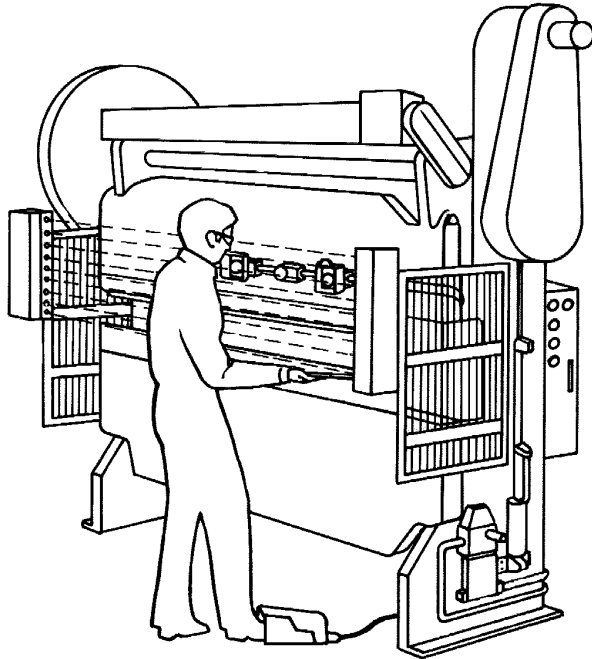

TWO-HAND CONTROL ON PRESS BRAKES

ANSI B11.3

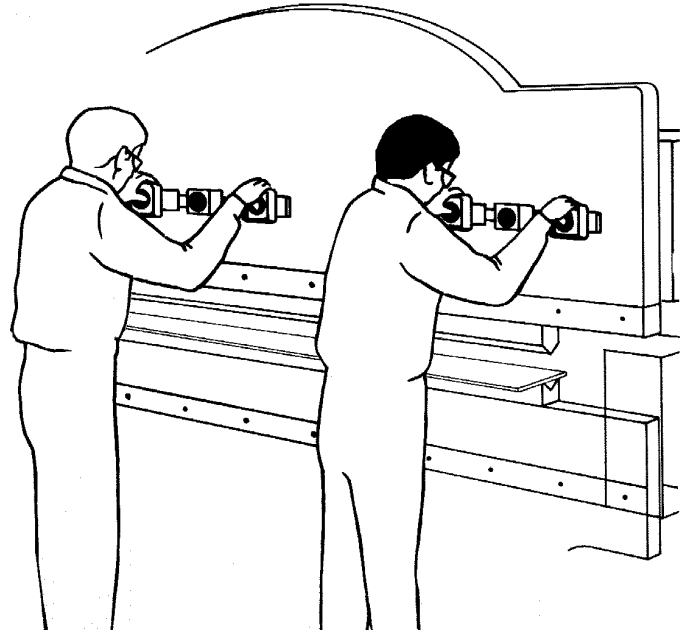

RESTRAINT (HOLDOUT) ON PRESS BRAKES

ANSI B11.3

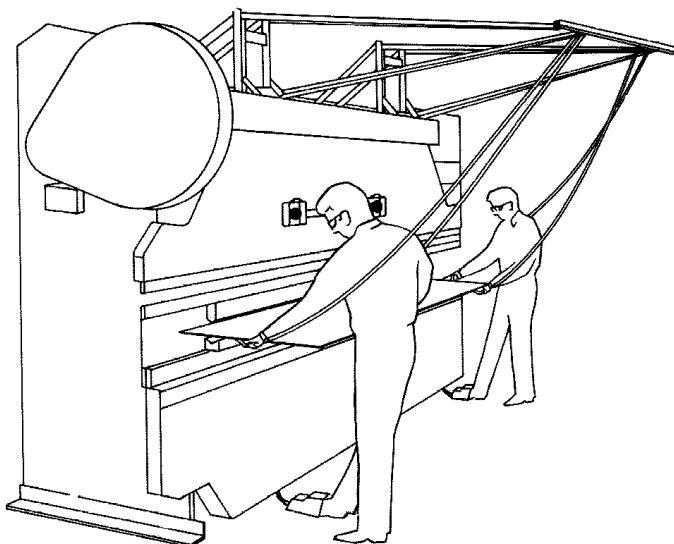

PULLBACK (PULL-OUT) ON PRESS BRAKES

ANSI B11.3

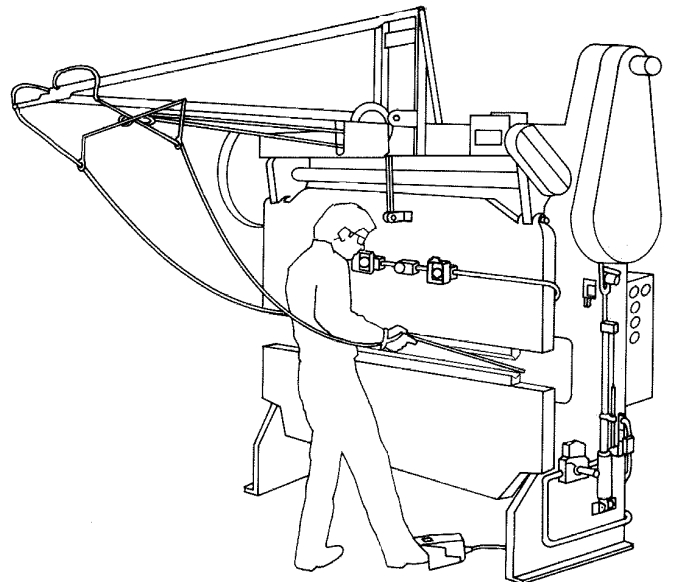

SECTION 9—METHODS OF SAFEGUARDING

SSC1500 Part-Revolution Solid-State Control

Auxiliary Safeguarding on Press Brakes

Auxiliary safeguarding can provide additional protection from injuries for all personnel in the machine area. It is most often used in conjunction with primary safeguarding devices. Auxiliary safeguarding also involves the guarding of other components or hazardous openings on machines.

Auxiliary safeguards include such items as point-of-operation side end barriers when light curtains are used, pressure-sensitive floor mats, workpiece tables or horizontal light curtains. Light curtains can be used horizontally to prevent an operator or other persons from standing between the vertical plane of light and the point-of-operation hazard.

Danger signs, used for warning, must be mounted on the machine in a position that is readily visible to the operator, setup person or other personnel. Hand tools can be used as auxiliary safeguarding. They are often used when feeding and retrieving small workpieces. Hand tools by themselves are NOT a point-of-operation safeguarding device.

ANSI B11.3—HAND TOOLS

Hand tools do not provide point-of-operation safeguarding—they are intended only for placing and removing materials in and from the press brake. They should be made of material that does not shatter if they get caught in the machine or its components. Hand tools should not create a hazard to the user based on their structure.



**Hand Tool Used for
Feeding Parts**

Other Safety Considerations

Other areas of machine safety must be considered in order to comply to the OSHA regulations and ANSI standards, as we know them. This includes, but is not limited to, items such as a main power disconnect switch, which must be provided for each machine, and a magnetic type motor starter for the main drive motor. All mechanical power-transmission apparatus of the machine, such as rotating flywheels, gears, sprockets, chains, and shafts, must be covered in accordance with OSHA 29 CFR 1910.219. As with all machinery, best safety practices must be a continuing program. The operator, die setter and all personnel must be fully trained and instructed on all safety procedures and have full knowledge of the safeguarding device being used.

When using any of the devices described for point-of-operation safeguarding, the sides and rear of the hazardous point-of-operation area must be safeguarded to protect the operator and other employees in the machine area (OSHA 29 CFR 1910.212).